



CHROMATOGRAPY

1

Dr. Praveen Katiyar

What is Chromatography?

- ❖ The word chromatography is derived from two greek word- Chroma means-colour and graphein- to write.
- ❖ Is a technique used to separate and identify the components of a mixture of biological fluids such as amino acids, carbohydrates & lipid etc..
- ❖ Works by allowing the molecules present in the mixture to distribute themselves between a stationary and a mobile medium.
- ❖ Molecules that spend most of their time in the mobile phase are carried along faster.
- ❖ Colour bands- separation of individual compounds.

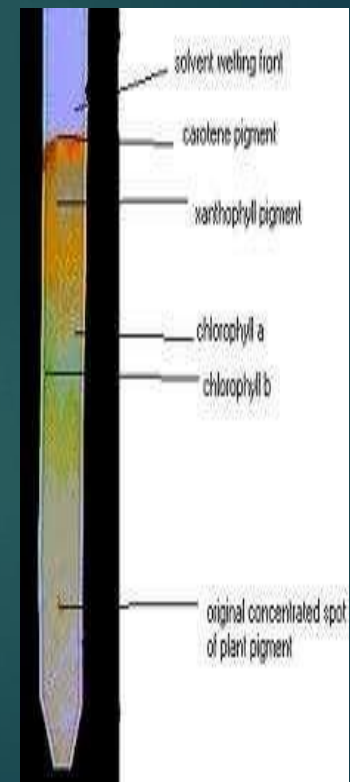

History

- ❖ 1903 Tswett - plant pigments separated on chalk columns
- ❖ 1931 Lederer & Kuhn - LC of carotenoids
- ❖ 1938 TLC and ion exchange
- ❖ 1950 Reverse phase LC
- ❖ 1954 Martin & Synge (Nobel Prize)
- ❖ 1959 Gel permeation
- ❖ 1965 instrumental LC (Waters)
- ❖ 12 Nobel prizes were awarded between 1937 and 1972 alone for work in which chromatography played a vital role.



Chromatography: Purpose

4

Analytical

- ❖ Determine Chemical composition of a sample

Preparative

- ❖ Used to purify sufficient quantities of a substance



Chromatography: Uses

Real-life examples of uses :

- ❖ Pharmaceutical Company – determine amount of each chemical found in new product
- ❖ Hospital – detect blood or alcohol levels in a patient's blood stream
- ❖ Law Enforcement – to compare a sample found at a crime scene to samples from suspects
- ❖ Environmental Agency – determine the level of pollutants in the water supply
- ❖ Manufacturing Plant – to purify a chemical needed to make a product

Chromatography: Terms used

6

- ❖ **Chromatograph**

Equipment that enables a sophisticated separation

Example- Gas chromatography or Liquid chromatography

- ❖ **Eluent**

Fluid entering column/ solvent that carries the analyte.

- ❖ **Eluate**

Mobile phase leaving the column.

- ❖ **Stationary phase - Immobilized phase**

- Immobilized on the support particles or on the inner wall of the column tubing.
- Examples : Silica layer - Thin Layer Chromatography

Chromatography: Terms used

7

- ❖ **Mobile phase –**
Moves in a definite direction. Liquid (LC), Gas (GC). The mobile phase moves through the chromatography column (the stationary phase) where the sample interacts with the stationary phase and is separated.
- ❖ **Retention time:**
Time taken for a particular analyte to pass through the system (from the column inlet to the detector) under set conditions.
- ❖ **Sample (Analyte) :**
Substance analyzed in chromatography.
- ❖ **Solvent:**
Any substance capable of solubilizing another substance.

Chromatography: Principle

- ❖ Chromatography is based on the principle of the partition of the solute between two immiscible phases.
- ❖ It usually consists of a mobile phase and a stationary phase.
- ❖ The mobile phase- usually refers to the mixture of the substances to be separated dissolved in a liquid or a gas.
- ❖ The stationary phase- it is a porous solid matrix through which the sample contained in the mobile phase percolates.
- ❖ The interaction between the mobile and the stationary phase result in the separation of the compounds from the mixture.
- ❖ These interaction include the physio chemical principles such as the adsorption, ion exchange, molecular sieving and affinity.

Factors Affecting The Separation

- ❖ Intermolecular interaction between the two phases.
- ❖ Extent of dispersion of solute molecules over the stationary phase.

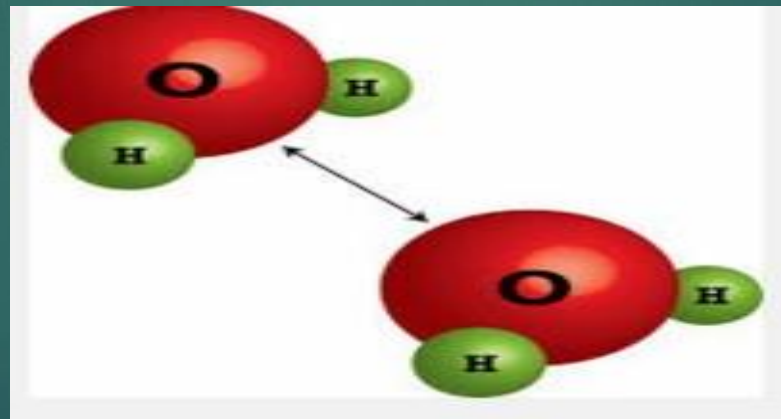

Chromatography : Classification

Two ways to classify methodology of chromatography:

1- Based on interaction between sample component or stationary phase or according to the force of separation-

- Partition
- Adsorption
- Ion exchange
- Gel filtration
- Affinity
- High performance liquid chromatography

Chromatography : Classification

2- Based on nature of stationary phase or mobile phase

- Planar- it may be paper or thin layer
 - Column it may be gas or liquid
-
- ❖ PLANAR chromatography is a separation technique in which the stationary phase is present as or on a plane.
 - ❖ Column chromatography is a separation technique in which the stationary bed is with in a tube.

Partition Chromatography

- ❖ It is used for the separation of mixture of amino acids & peptides.
- ❖ The molecules of a mixture get partitioned between the stationary and the mobile phase depending on the relative affinity of each one of the phases.

- ❖ Undertaken in 2 ways
 - ❖ 1- Paper Chromatography
 - ❖ 2- Thin layer chromatography

Paper Chromatography

- ❖ An analytical technique for the separation and identifying mixtures that are either coloured or can be made coloured.
- ❖ It is liquid partition chromatography.
- ❖ Used for the separation of amino acids, sugars, sugar derivatives and peptides.

In the Paper chromatography-

- 1- Stationary phase is water held on a solid support of filter paper(cellulose, Whatman grade)
- 2- Mobile phase is a mixture of immiscible solvents, which are mixtures of water, a non polar solvent and an acid or base e.g. Butanol, acetic acid water or phenol water.

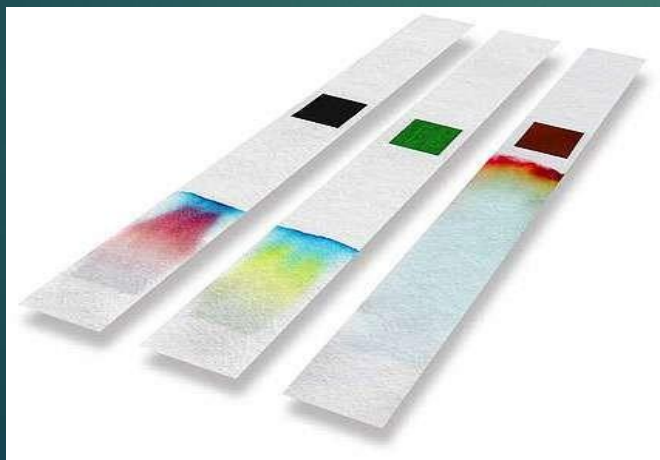

Paper Chromatography- Procedure

14

- ❖ Take a narrow strip of Whatman grade paper. Hold it at the top.
- ❖ A small spot of sample is applied to this paper about 2.5 centimetre from the lower end. This sample is absorbed onto the paper and may form interactions with it.
- ❖ The paper is then dipped in to a suitable solvent, such as ethanol or water, taking care that spot is above the surface of the solvent and placed in in a sealed container.
- ❖ The solvent moves up the paper by capillary action and dissolves the sample mixture which will travel up the paper with the solvent solute sample.
- ❖ Different compounds in the sample mixture travel at different rates due to differences in the solubility in the solvent, and due to difference in their attraction to the fibres in the paper.
- ❖ Paper Chromatography takes any where from several minutes to several hours.

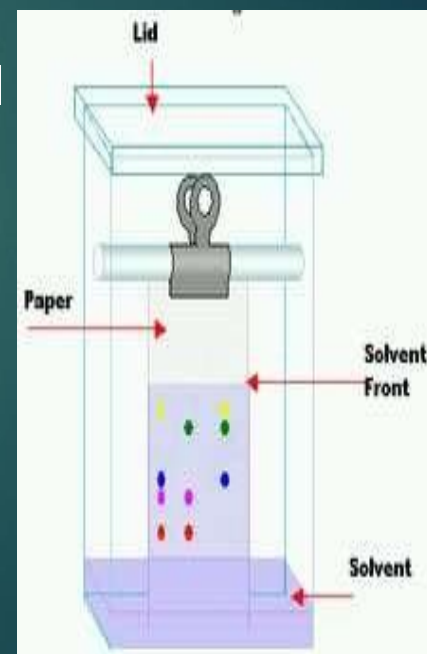

Ascending and Descending Paper Chromatography

❖ Ascending Paper Chromatography-

- In this method, the solvent is in pool at the bottom of the vessel in which the paper is supported. It rises up the paper by capillary action against the force of the gravity.

❖ Descending Paper Chromatography-

- In this method, the solvent is kept in a trough at the top of the chamber and is allowed to flow down the paper. The liquid moves down by the capillary action as well as gravitational force.
- The substances which can not be separated by ascending method, can be separated by the descending method.

Paper Chromatography- Analysis

16

- ❖ After development, the spots corresponding to different compounds may be located by their color, ultraviolet light, ninhydrin or by treatment with iodine vapors.
- ❖ The paper remaining after the experiment is known as the chromatogram.
- ❖ The spots may be identified by the R_f value of the unknown substance and comparing with those of pure standards.
- ❖ The components which have been separated differ in their R_f value i.e. ratio of distance travelled from the spot or origin by the solute component to that of the distance travelled from the spot or origin by the solvent.

$$R_f = \frac{\text{Distance travelled by a Solute}}{\text{Distance travelled by a Solvent}}$$

- ❖ R_f is known as Retention factor or Ratio of Fronts.
- ❖ The R_f value is a constant for a particular solvent system at a given temperature.
- ❖ If R_f value of a solution is zero, the solute remains in the stationary phase and thus it is immobile.
- ❖ If R_f value=1 then the solute has no affinity for the stationary phase and travels with the solvent front.
- ❖ Retention factor can never be greater than one.

Two dimensional Paper Chromatography

17

- ❖ Some times it is difficult to separate complex mixture of substances by a single run with one solvent system.
- ❖ In such a case, a second run is carried out by a different solvent system, in a direction perpendicular to the first run.
- ❖ This is referred to as two dimensional paper chromatography which enhances the separation of a mixture in to individual components.

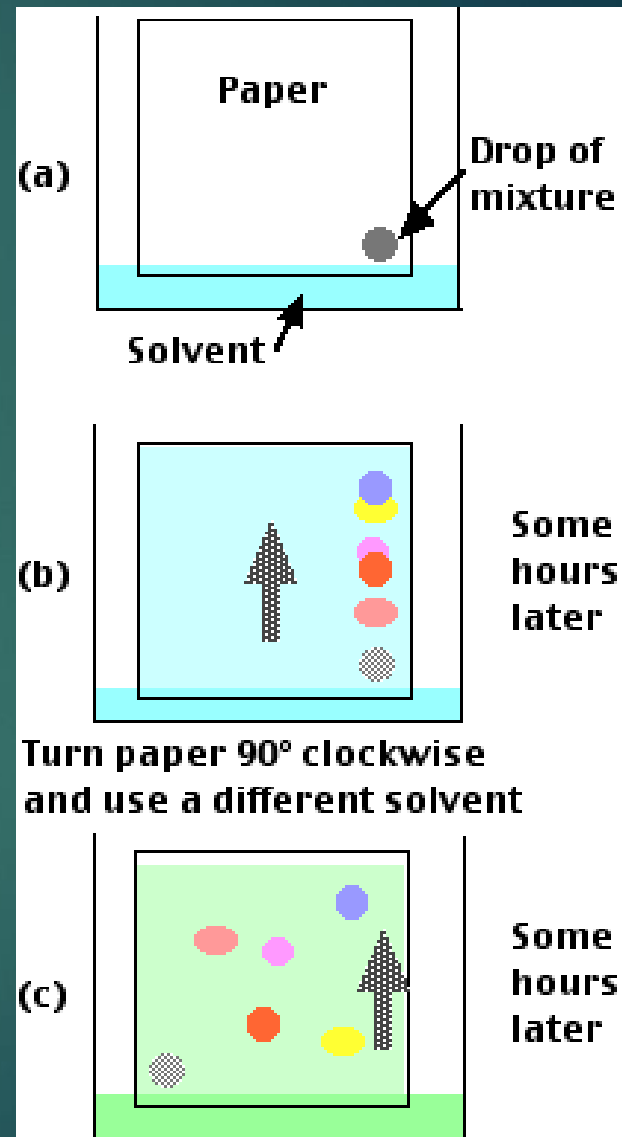

Significance of Paper Chromatography

- ❖ It is a very easy, simple, rapid and highly efficient method of separation.
- ❖ It can be applied even in microgram quantities of the sample.
- ❖ It can be used for the separation of a wide variety of materials like amino acids, oligopeptides, sugars, oligosaccharides, glycosides, purines & pyrimidines, steroids, vitamins, some alkaloids like penicillin, tetracycline and streptomycin.
- ❖ It is not preferred for separating proteins because they are not soluble in many of the solvent systems and are also denatured by them.
- ❖ Paper chromatography is inferior to Thin layer chromatography in resolving power.

Thin Layer Chromatography

19

- ❖ It is a chromatographic technique, used to separate mixtures.
- ❖ It involves a stationary phase consisting of a thin layer of adsorbent material, usually silica gel, aluminium oxide or cellulose immobilized on to a flat, inert carrier sheet.
- ❖ A liquid phase consisting of the solution to be separated which is dissolved in an appropriate solvent and is drawn up the plate via capillary action, separating the solution based on the polarity of the components of the compound in question.

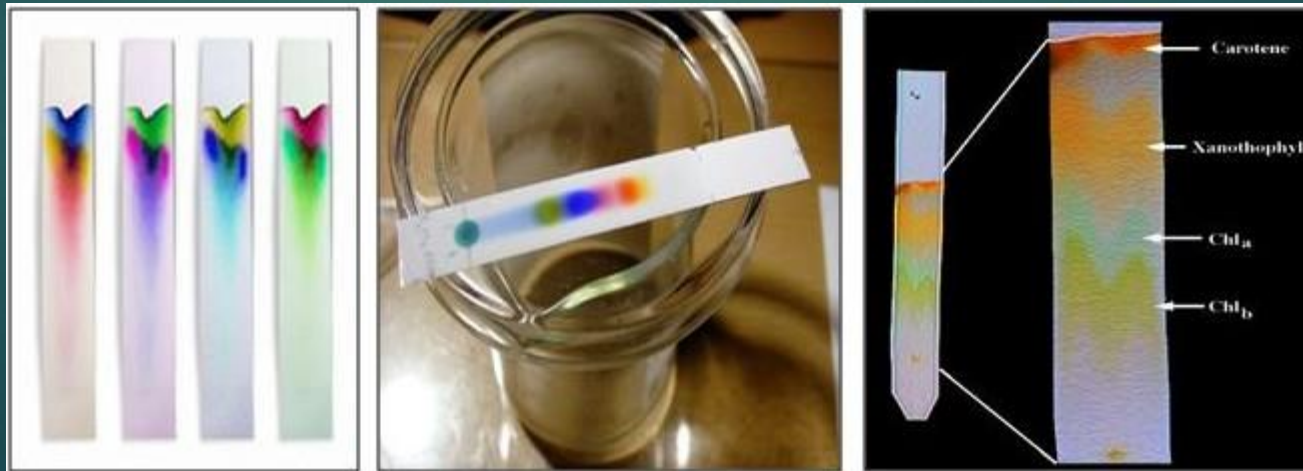

Thin Layer Chromatography- Procedure

20

- ❖ The process is similar to Paper Chromatography with the advantage of faster runs, better separations and the choice between different stationary phases.
- ❖ A small spot of solution containing the sample is applied to a plate, about one centimetre from the base.
- ❖ The plate is then dipped in to a suitable solvent, such as hexane or ethyl acetate, and placed in a sealed container.
- ❖ The solvent moves up the plate by capillary action and meets the sample mixture, which is dissolved & is carried up the plate by the solvent.
- ❖ Different compounds in the sample mixture travel at different rates due to the differences in their attraction to the stationary phase, and because of differences in solubility in the solvent.

Thin Layer Chromatography

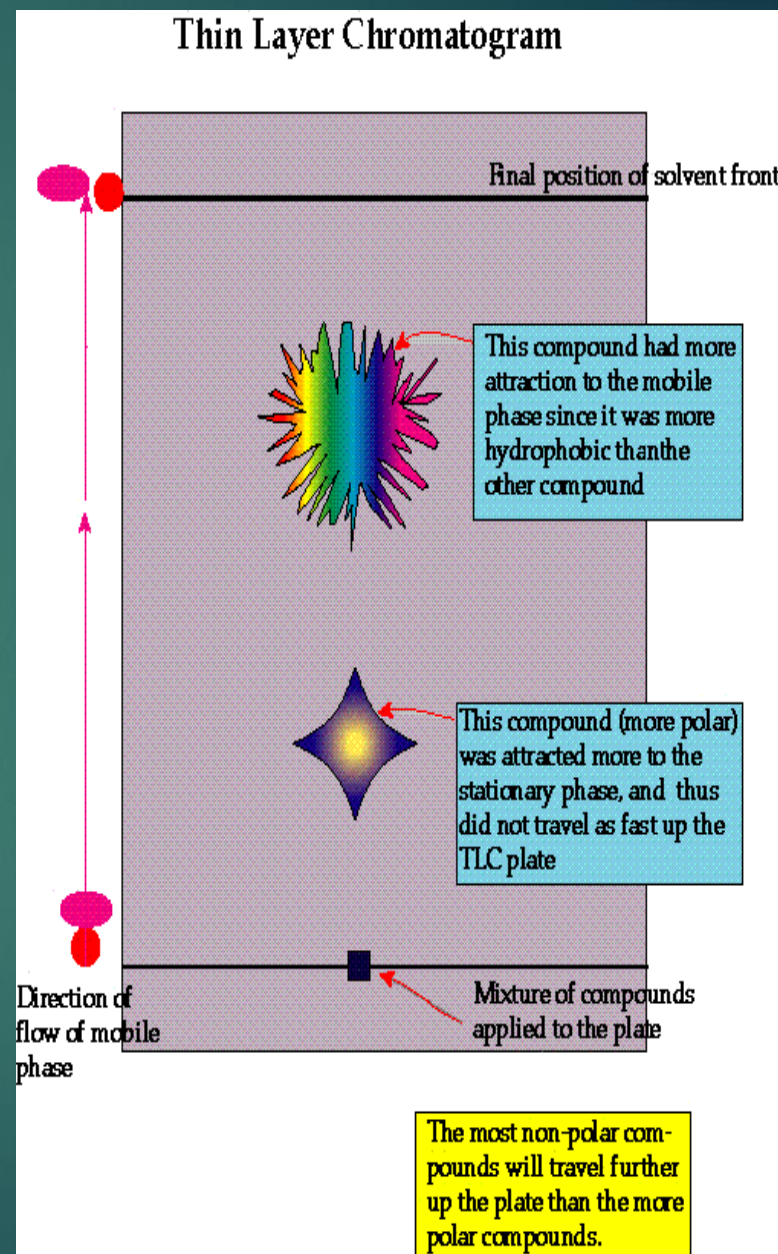
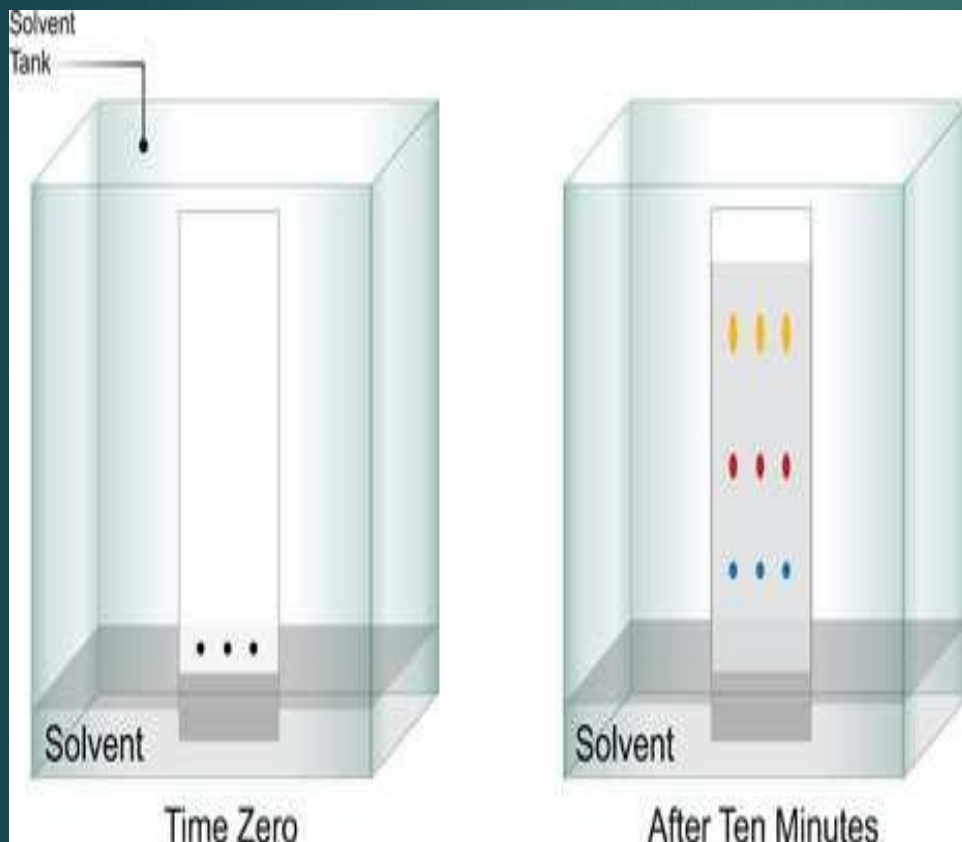

Thin Layer Chromatography- Significance

22

Wide range of uses include

- ❖ Determination of the pigments a plant contains
- ❖ Detection of Pesticides or insecticides
- ❖ Identifying compounds present in a given substance
- ❖ Monitoring organic reactions

Advantage of TLC over Paper Chromatography

23

- ❖ TLC takes less time-
TLC takes only 3-4 hrs for separation of components
Paper chromatography takes 14-16 hrs.
- ❖ Corrosive reagents like sulphuric acid can also be used in TLC.
- ❖ Separation & visualization of components is easier in TLC than paper chromatography.
- ❖ TLC has capacity to analyse the multiple samples in a single run.
- ❖ TLC is relatively a low cost.

Adsorption Chromatography

24

- ❖ In this separation is based on differences in adsorption at the surface of the solid stationary medium.
- ❖ The adsorbents such as silica gel, charcoal powder and calcium hydroxyapatite are packed in to a column in a glass tube. This serves as the stationary phase. The sample mixture in a solvent is loaded on this column.
- ❖ The individual components get differently adsorbed on to the adsorbent.

Adsorption Chromatography- Elution

25

- ❖ The elution is carried out by a buffer system(mobile phase). The most weakly held fraction moves fastest, followed by others, according to the order of tightness in adsorption.
- ❖ The individual compounds come out of the column at different rates which may be separately collected and identified.
- ❖ Amino acids may be identified by Ninhydrin colorimetric method.
- ❖ An automated column chromatography apparatus- Fraction Collector is frequently used now a days.

Ion- Exchange Chromatography

- ❖ Also known as Ion chromatography.
- ❖ It allows the separation of ions and polar molecules based on the charge properties of the molecule.
- ❖ It can be used for almost any kind of charged molecule including large proteins, small nucleotides and amino acids.
- ❖ The solution to be injected is usually called a sample, and the individually separated components are called analytes.
- ❖ It is often used in protein purification, water analysis and quality control.

Ion- Exchange Chromatography

- ❖ It retains analyte molecules based on coulombic (ionic) interactions.
- ❖ The stationary phase surface displays ionic functional groups that interact with analyte ions of opposite charge.

- ❖ Sub division-
 1. Cation Exchange Chromatography- it retains positively charged cations because the stationary phase displays a negatively charged functional group.
 2. Anion exchange chromatography retains anions using positively charged functional group.

Ion- Exchange Chromatography- Procedure

- ❖ A mixture of amino acids or proteins can be conveniently separated by ion exchange chromatography.
- ❖ The amino acid mixture (at pH around 3) is passed through a cation exchange and the individual amino acid can be eluted by using buffers of different pH.

Example- A mixture of Arginine and Aspartic acid is passed through a cation exchange column. Arginine has extra positive charge and so adheres to the column. But negatively charged Aspartic acid molecules will not adhere and come out first from the column.

- ❖ When weak NaOH is passed, the positive charge of Arginine is neutralized.
- ❖ Na⁺ will replace Arginine in the column, thus Arginine is eluted finally.
- ❖ The various fractions eluted, containing individual amino acids, are allowed to react with Ninhydrin reagent to form coloured complexes.
- ❖ This is continuously monitored for qualitative and quantitative identification of amino acids.
- ❖ The Amino acid analyser is based on this method.

Ion- Exchange Chromatography- Types of Resins

30

Various types of ion exchange resins are commercially available.

❖ Cation exchange resins:

- Polystyrene sulfonate resins, CM-Sephadex gel, CM- Cellulose
- These have acidic groups and immobilize cations from adjacent solutions.

❖ Anion exchangers:

- DEAE Cellulose, Trimethyl amino polystyrene, DEAE-Sephadex.
- These have basic groups and immobilize anions from neighbouring solutions.

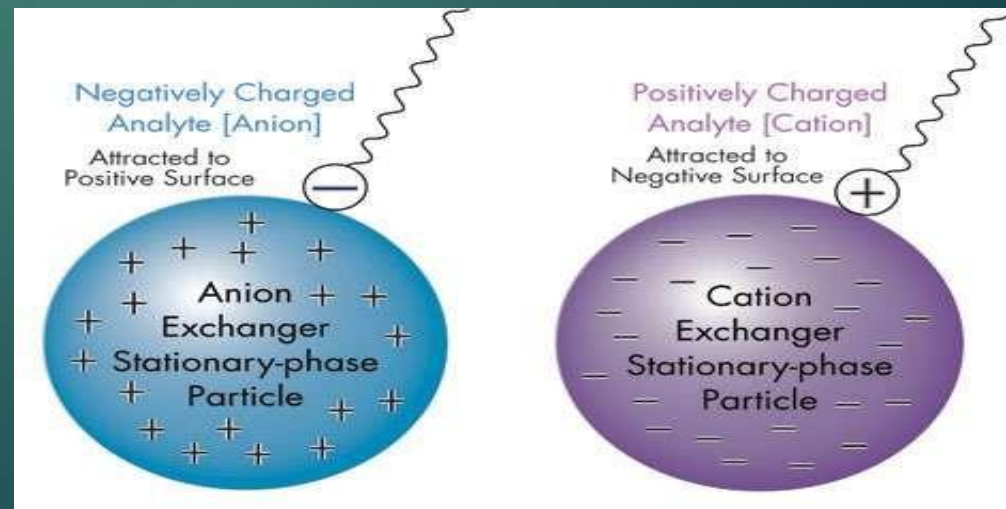

Ion-Exchange Chromatography- An Over View

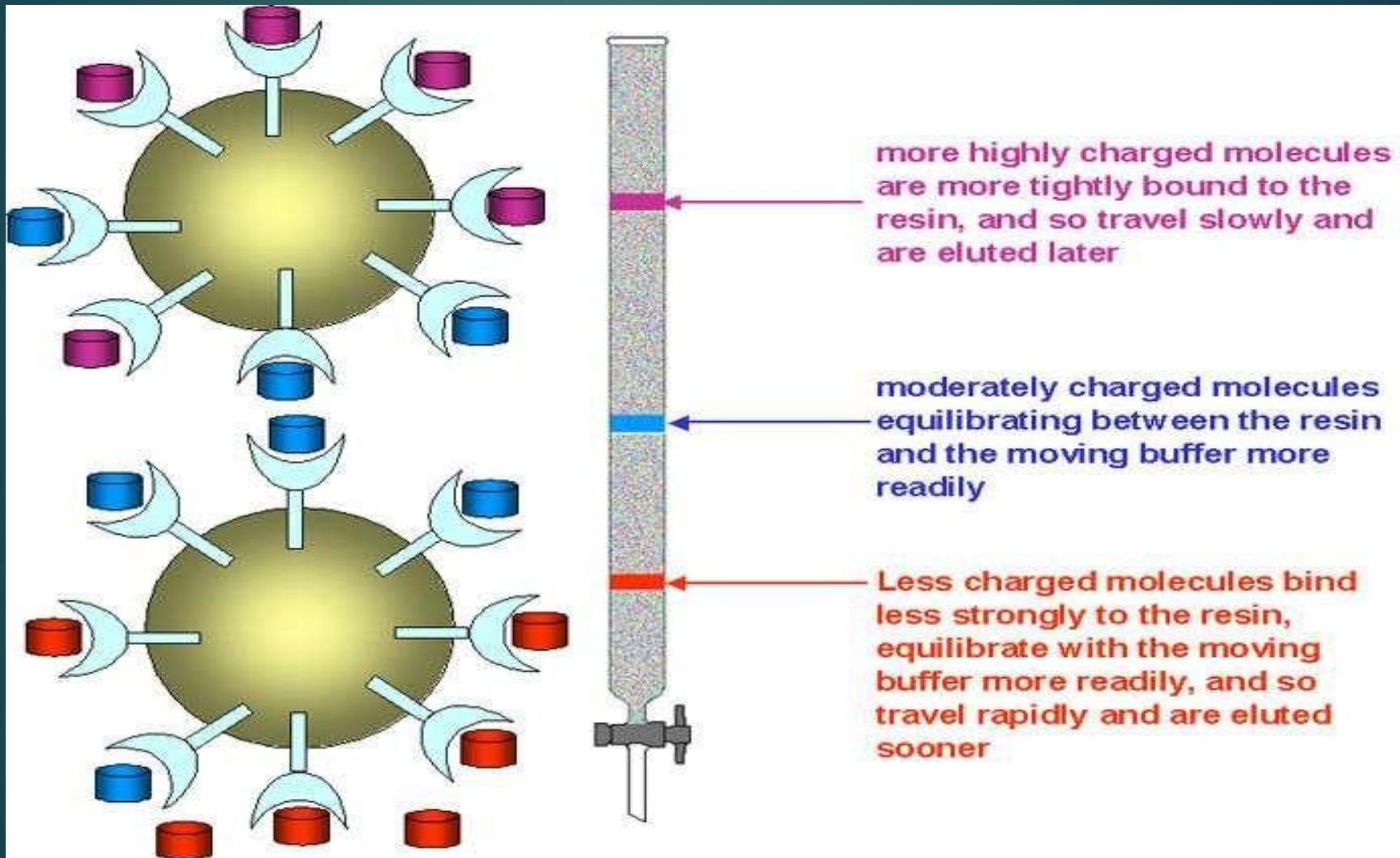

Gel Filtration Chromatography or Molecular Sieve Chromatography

32

- ❖ This is extremely useful in separating ribosomes, viruses, nucleic acids and proteins depending on their particle sizes & shapes.
- ❖ Separation of particles is based on their size, shape and molecular weight.
- ❖ This technique is also referred to as Molecular exclusion chromatography.
- ❖ The apparatus consists of a column packed with sponge like gel beads (usually cross- linked polysaccharides) containing pores.
- ❖ The gels serve as molecular sieves for the separation of smaller and bigger molecules.
- ❖ The solution mixture containing molecules of different sizes (say protein) is applied to the column and eluted with a buffer.

Gel Filtration Chromatography or Molecular Sieve Chromatography

33

- ❖ The larger molecules can not pass through the pores of a gel and therefore move faster.
- ❖ The smaller molecule enter the gel beads and are left behind, which come out slowly. By selecting gel beads of different porosity, the molecules can be separated.
- ❖ Gel filtration chromatography can be used for the approximate determination of molecular weights. This is done by using a calibrated column with substances of known molecular weights.

Gel Filtration Chromatography or Molecular Sieve Chromatography

34

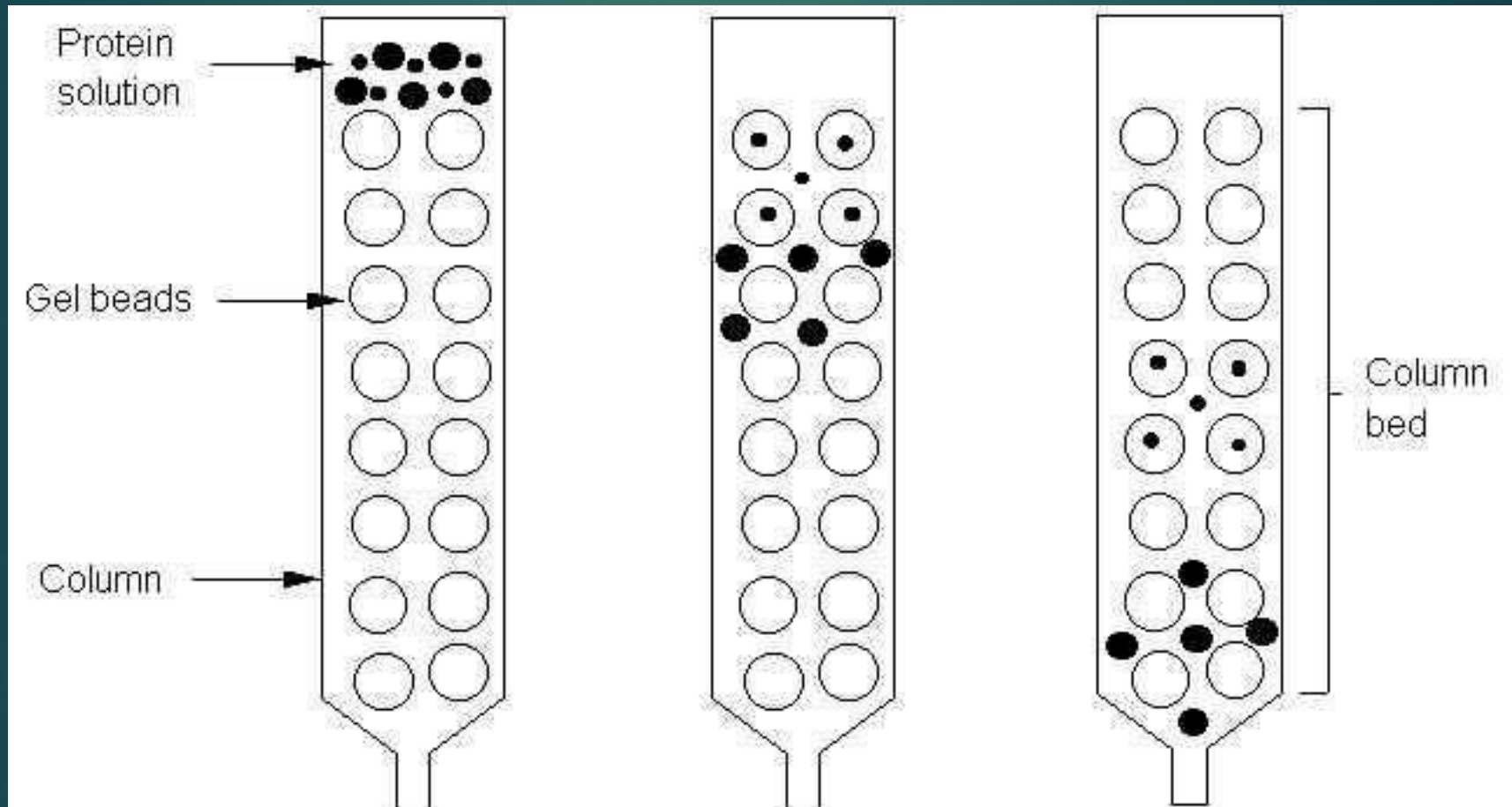

Larger particles come out first, while smaller particles come in later fractions

Affinity Chromatography

35

- ❖ Principle:
 - It is based on the property of specific and non covalent binding of proteins to other molecules, referred to as substrate or cofactors.
- ❖ This technique involves the use of ligands covalently attached to an inert and porous matrix in a column. The immobilized ligands act as molecular hooks to selectively pick up the desired protein while the remaining proteins pass through the column.
- ❖ The desired protein captured by the ligands, can be eluted by using free ligand molecules.
- ❖ Alternatively, some reagents that can break protein ligand interactions can also be employed for the separation.

Affinity Chromatography- Significance

36

- ❖ It is useful for the purification of enzymes, vitamins, nucleic acids, drugs, hormone receptors, antibodies etc.
- ❖ It is also widely used for the estimation of Glycated Hb. Normal Hb does not bind and comes out first, while glycated Hb bind with the Boronic Acid, used as a ligand. Sorbitol is then added to elute the Glycated Hb, which can be quantitated then.
- ❖ By using antibodies, antigens can be easily separated. Conversely, antibodies can be purified by passing through a column containing the antigen

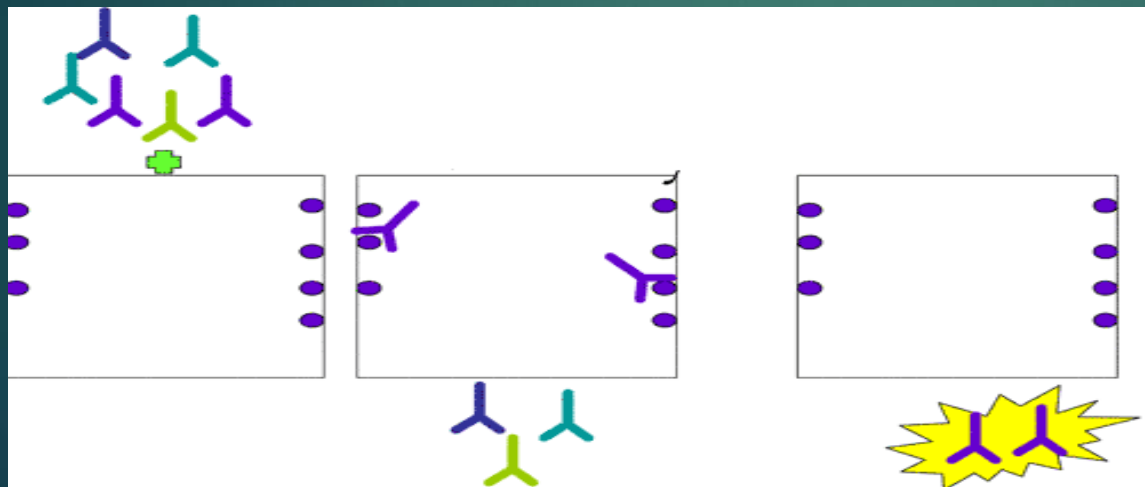

Specific Antibody binds to a specific antigen attached to the stationary medium, the remaining antibodies come out in earlier fractions.

High Performance Liquid Chromatography (HPLC)

37

- ❖ Chromatographic techniques are slow and time consuming. The separation can be greatly improved by applying high pressure in the range of 5000-10000 pounds per square inch, hence this technique is also called High Pressure Liquid Chromatography.
- ❖ HPLC requires the use of non compressible resin materials & strong metal columns. The eluents of the columns are detected by methods such as UV absorption and fluorescence.
- ❖ It can be applied in the form of partition, adsorption, ion exchange or gel filtration chromatography.
- ❖ The stationary phase- it consists of an immobilized thin layer of a liquid on the micro glass or plastic beads, tightly packed in to a narrow column.
- ❖ The mobile phase- it consists of a buffered solvent system, which is passed under high pressure through the column for eluting the solute of the same.

High Performance Liquid Chromatography (HPLC)- Significance

38

- ❖ Due to rapidity in action it is used for assaying amino acids, peptide, proteins, carbohydrates, lipids, nucleic acids & related compounds, vitamins, hormones, metabolites and drugs such as antiarrhythmics, antibodies, antiepileptics, analgesics, bronchial smooth muscle relaxants and antidepressants.
- ❖ It detects very small amounts
- ❖ Speed, efficiency, sensitivity and ease of operation.
- ❖ High degree of versatility.
- ❖ Easily separate a wide variety of chemical mixtures.

High Performance Liquid Chromatography (HPLC)- Apparatus

39

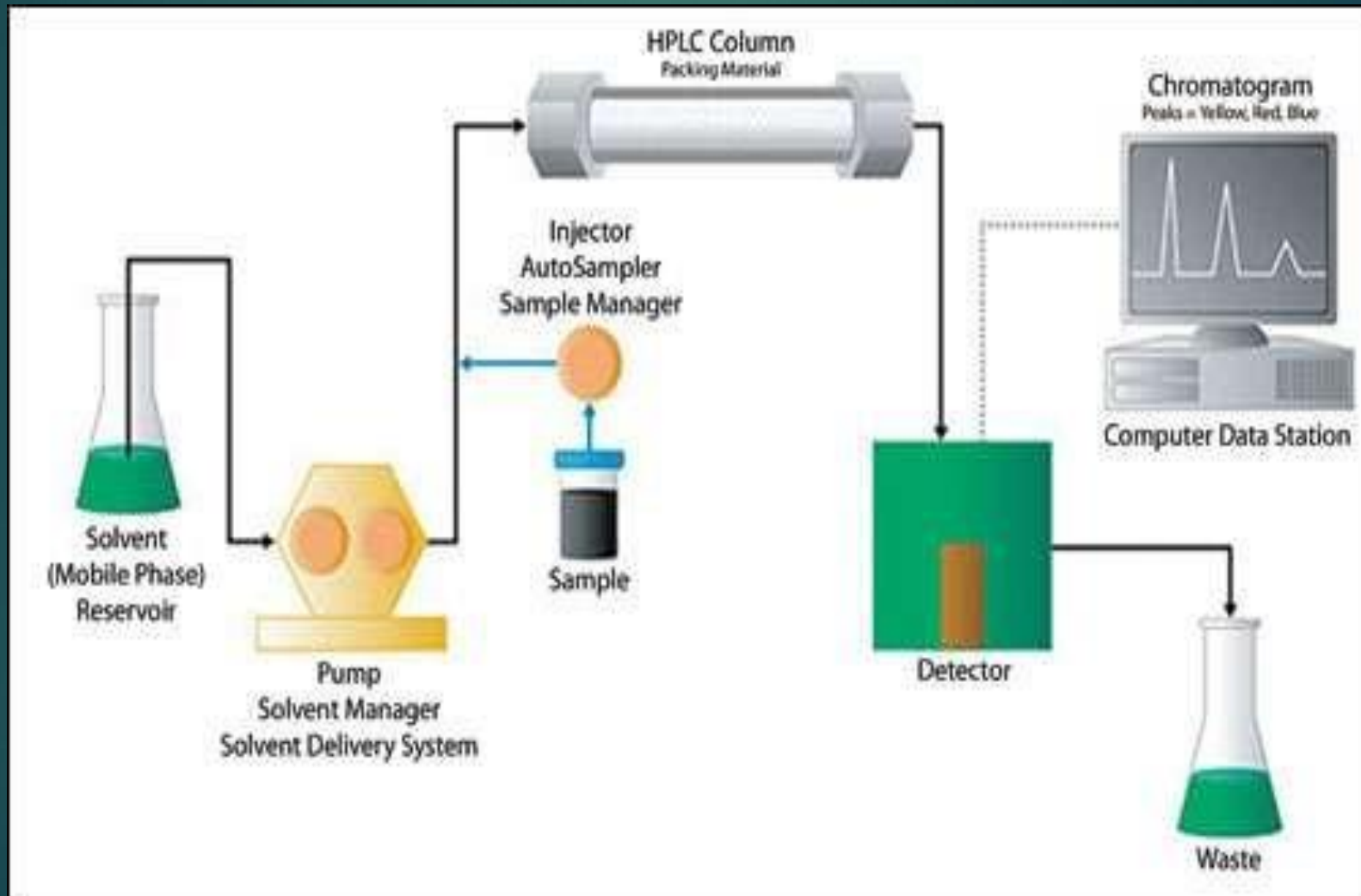

Gas Liquid Chromatography

40

- ❖ Gas Liquid Chromatography is method of choice for the separation of volatile substances or volatile derivatives of certain involatile substances.
- ❖ The stationary phase is an inert solid material (diatomaceous earth or powdered firebrick), impregnated with a non volatile liquid (silicon or poly ethylene glycol). This is packed in a narrow column and maintained at high temperature (around 200 degree celcius).
- ❖ A mixture of volatile material is injected in to the column along with the mobile phase, which is an inert gas (argon, helium or nitrogen).

Gas Liquid Chromatography

41

- ❖ The separation of volatile material is based on the partition of the components between the mobile phase(gas) and stationary phase(liquid), hence the name is Gas Liquid Chromatography.
- ❖ The separated compounds can be identified and quantitated by a detector.
- ❖ It is sensitive, rapid and reliable.
- ❖ It is frequently used for the quantitative estimations of biological materials such as lipids, drugs & vitamins.

Gas Liquid Chromatography-Apparatus

42

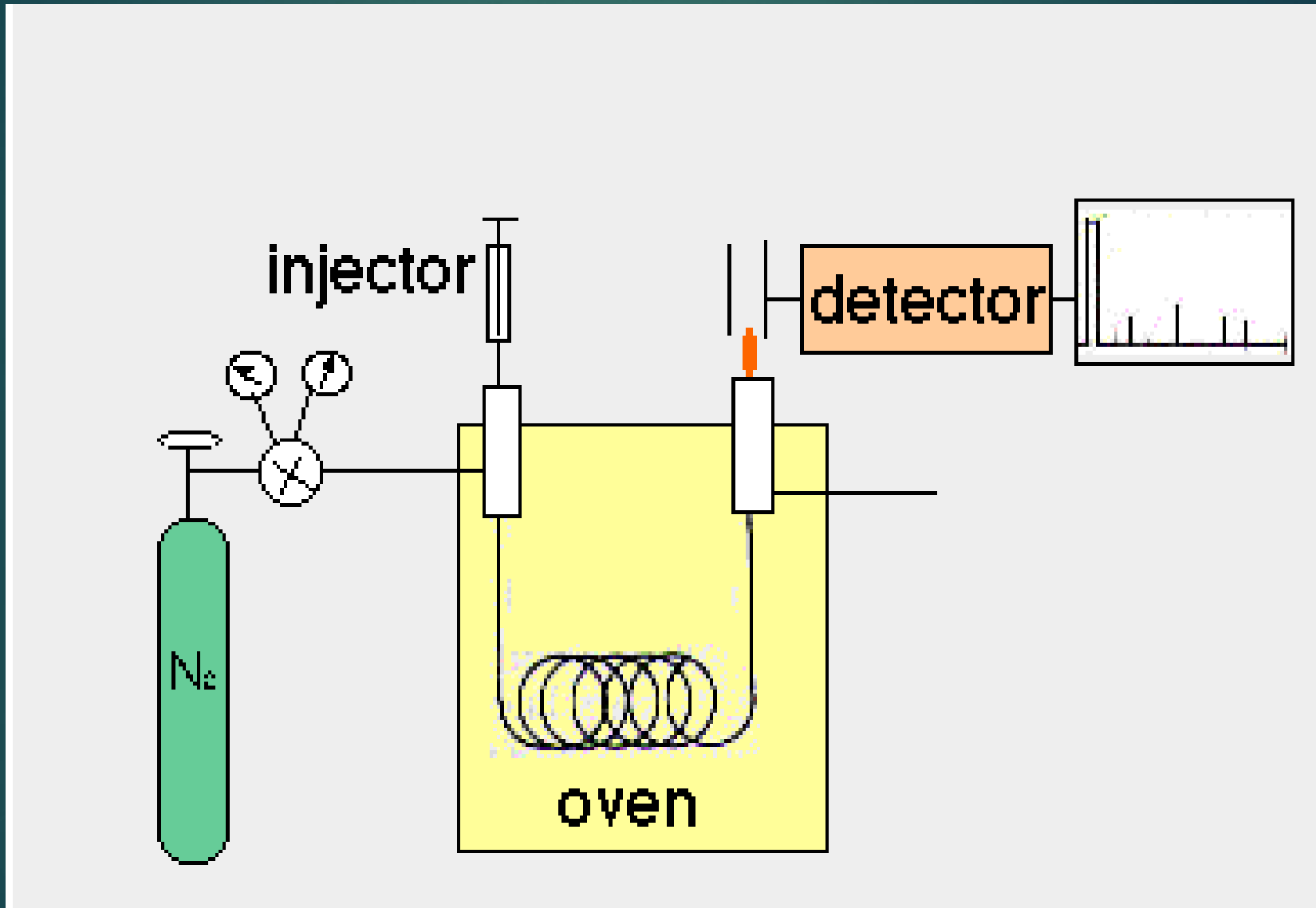

Summary

43

