

Layered Network Architecture, Review of ISO-OSI Model

PROTOCOLS

- *A protocol is synonymous with rule. It consists of a set of rules that govern data communications. It determines what is communicated, how it is communicated and when it is communicated. The key elements of a protocol are syntax, semantics and timing*

Elements of a Protocol

- **Syntax**
 - Structure or format of the data
 - Indicates how to read the bits - field delineation
- **Semantics**
 - Interprets the meaning of the bits
 - Knows which fields define what action
- **Timing**
 - When data should be sent and what
 - Speed at which data should be sent or speed at which it is being received.

LAYERED TASKS

- *Established in 1947, the International Standards Organization (ISO) is a multinational body dedicated to worldwide agreement on international standards. An ISO standard that covers all aspects of network communications is the Open Systems Interconnection (OSI) model. It was first introduced in the late 1970s.*

Tasks involved in sending a letter

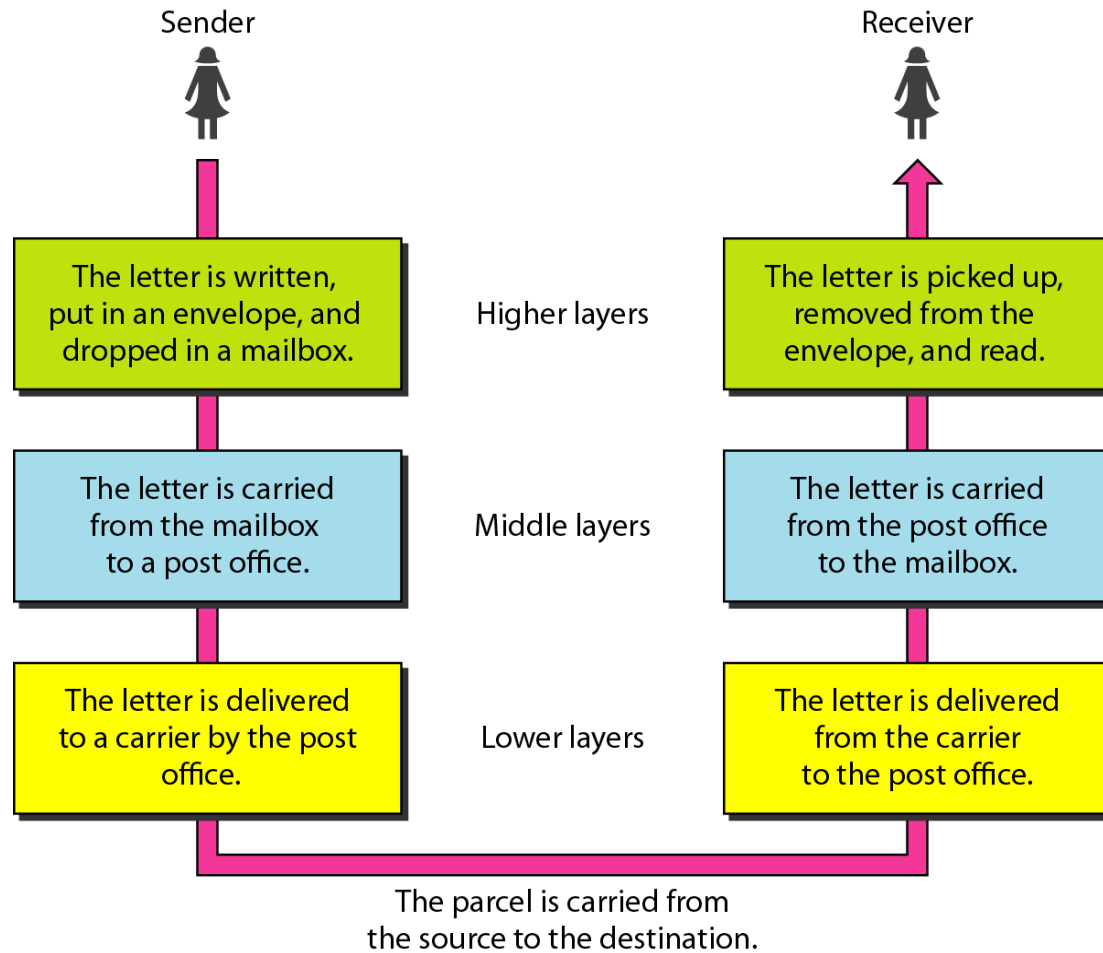

THE OSI MODEL

- *Established in 1947, the International Standards Organization (ISO) is a multinational body dedicated to worldwide agreement on international standards. An ISO standard that covers all aspects of network communications is the Open Systems Interconnection (OSI) model. It was first introduced in the late 1970s.*
- ISO is the organization.
OSI is the model.

Seven layers of the OSI model

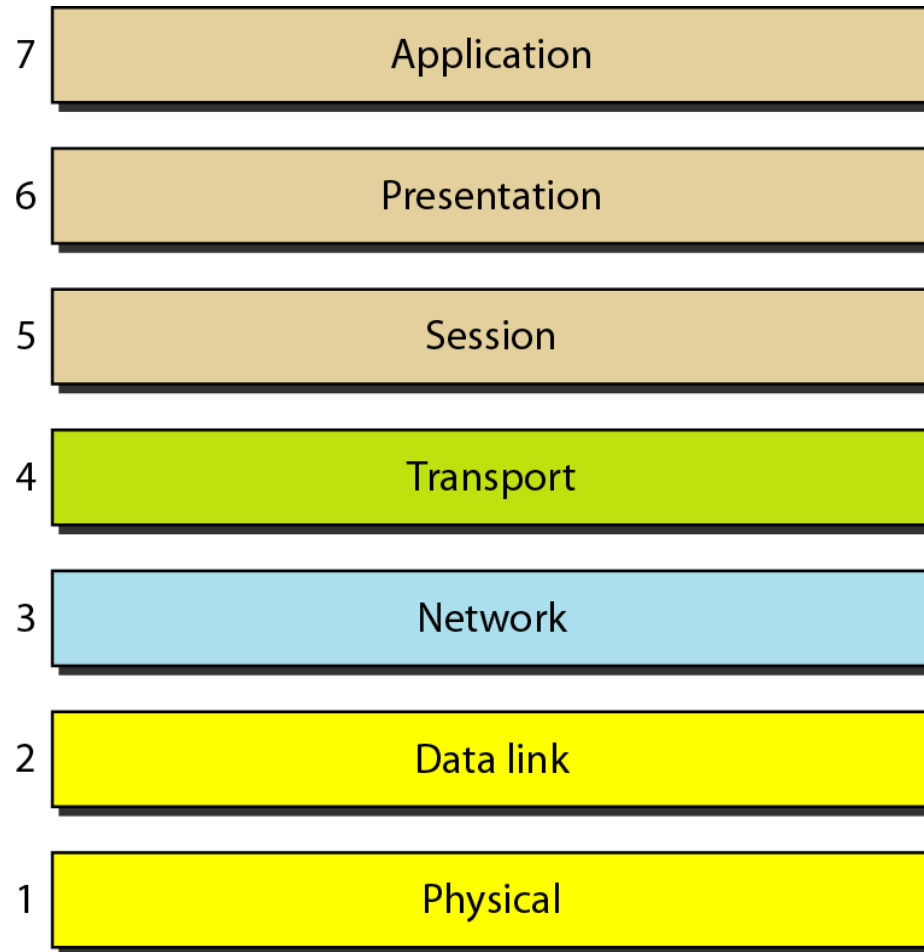

The interaction between layers in the OSI model

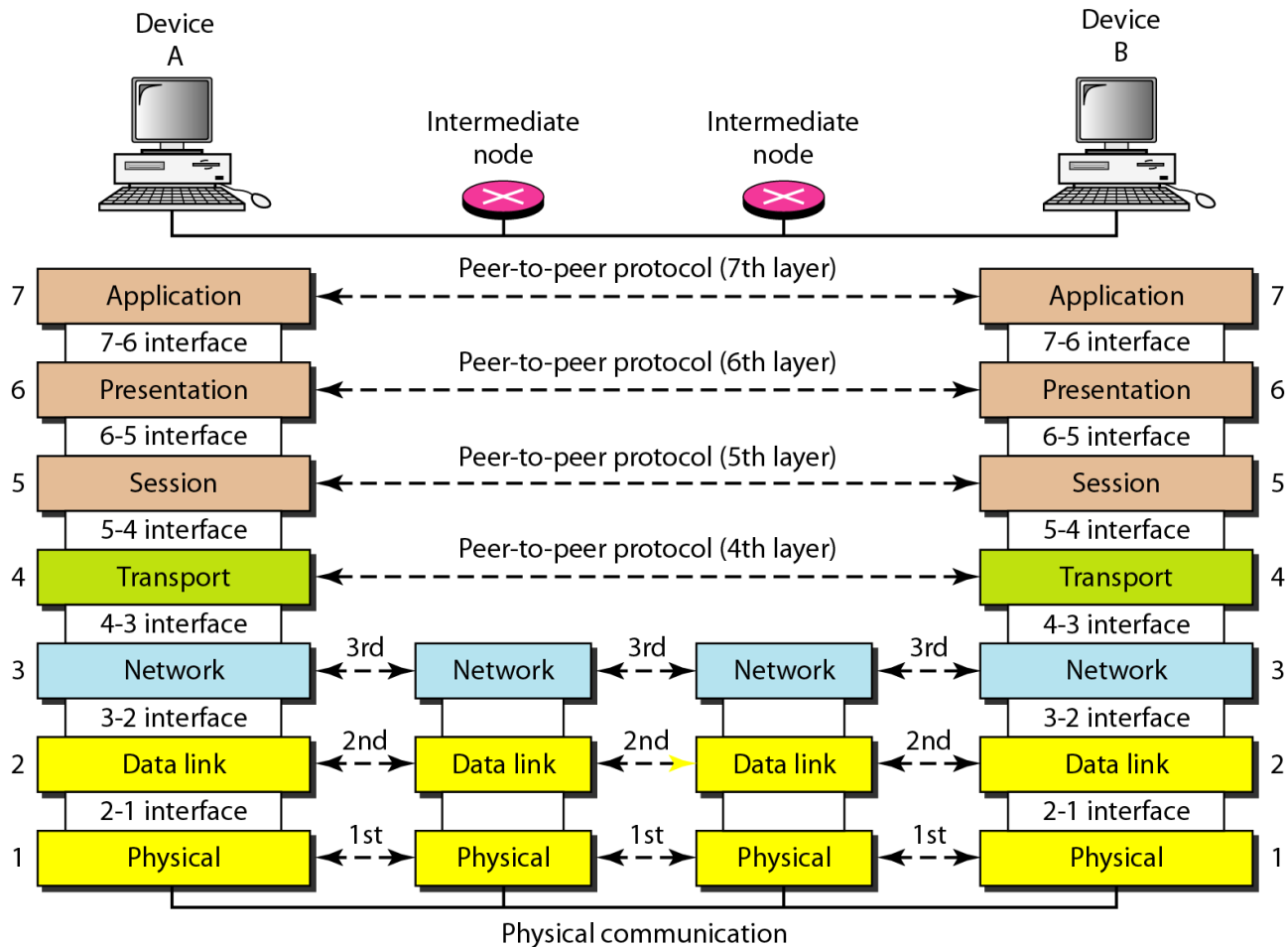

An exchange using the OSI model

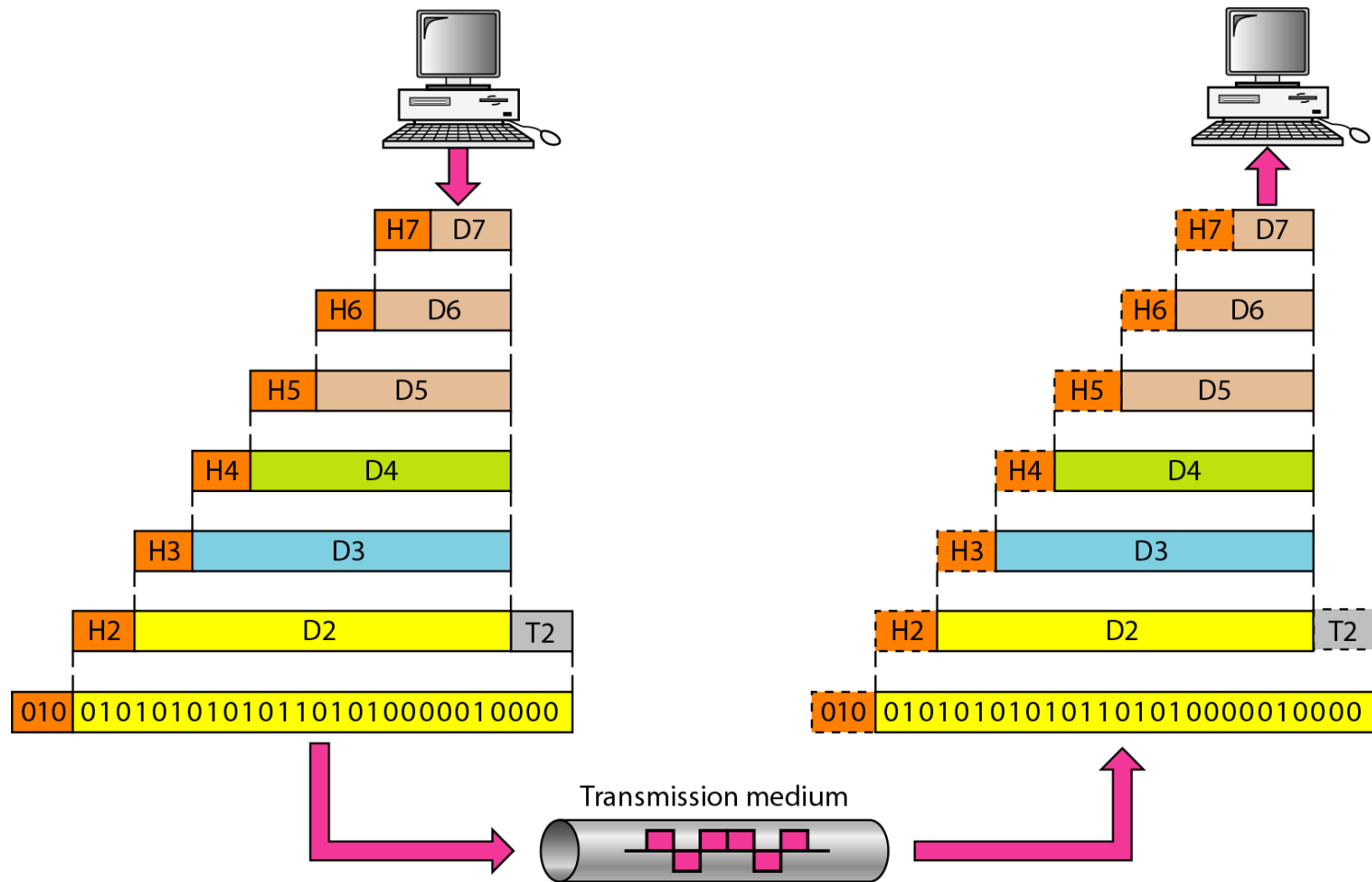

LAYERS IN THE OSI MODEL

1. Physical Layer
2. Data Link Layer
3. Network Layer
4. Transport Layer
5. Session Layer
6. Presentation Layer
7. Application Layer

Physical layer:

- The physical layer is responsible for movements of individual bits from one hop (node) to the next.

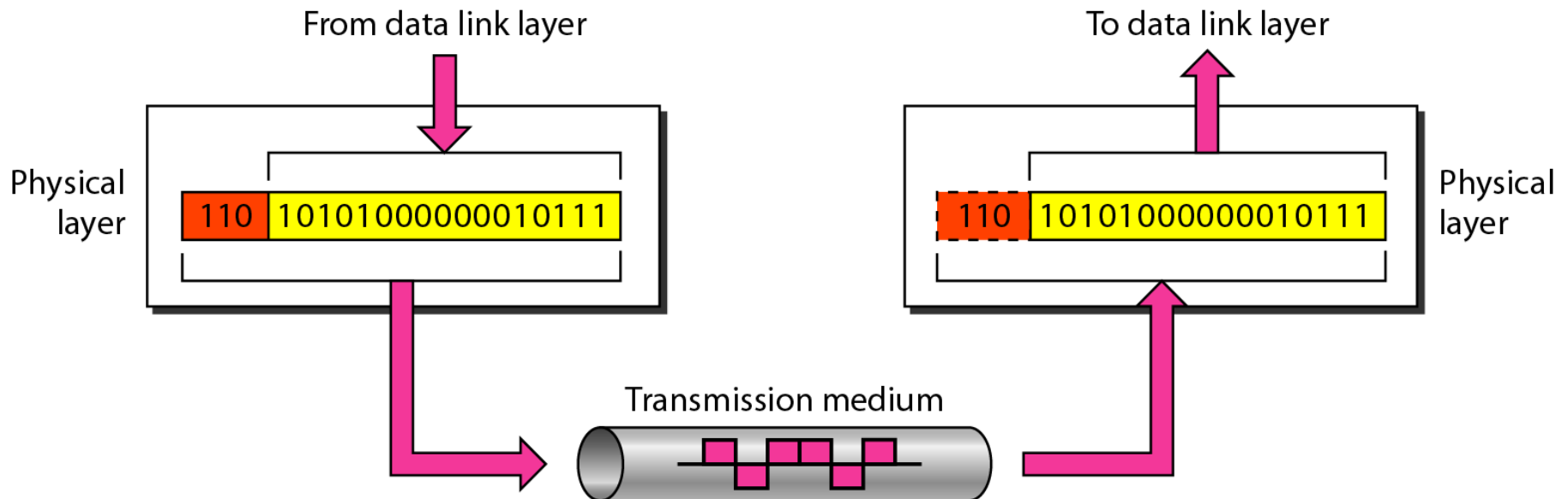

Data link layer

- The data link layer is responsible for moving frames from one hop (node) to the next.

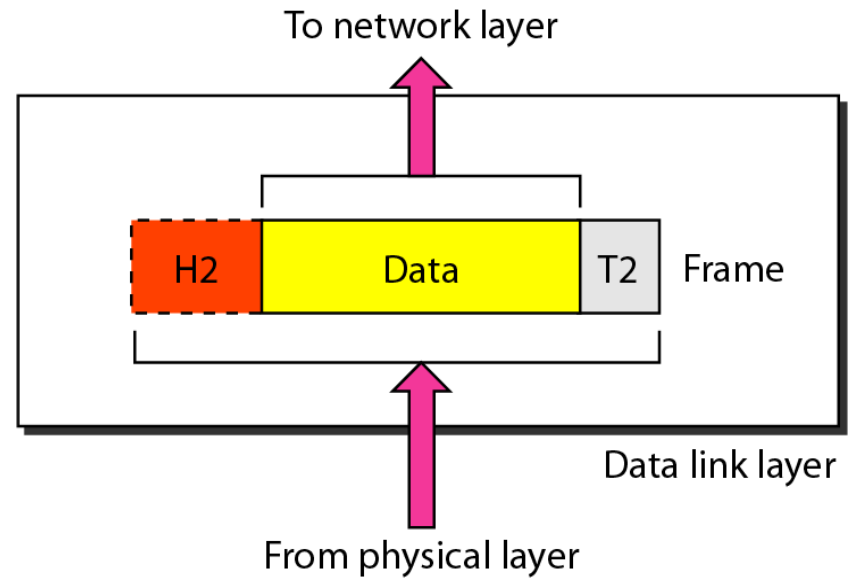
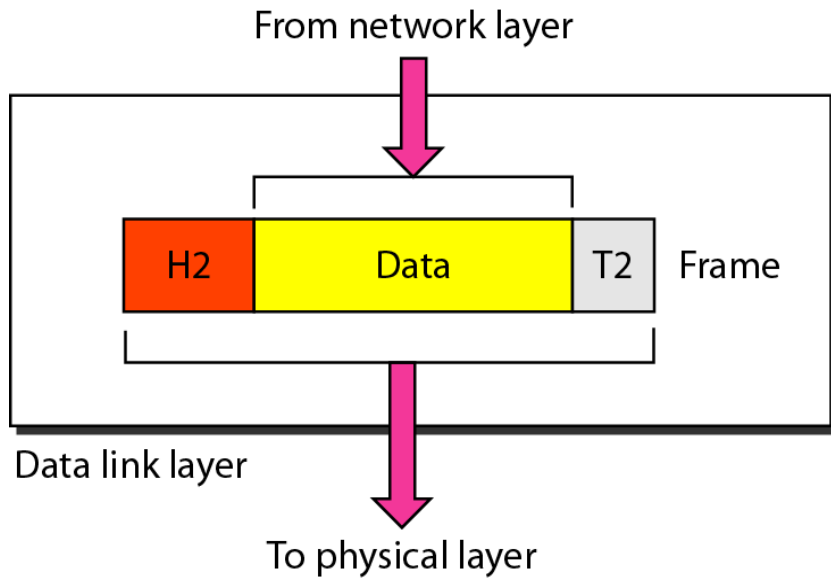

Source-to-destination delivery

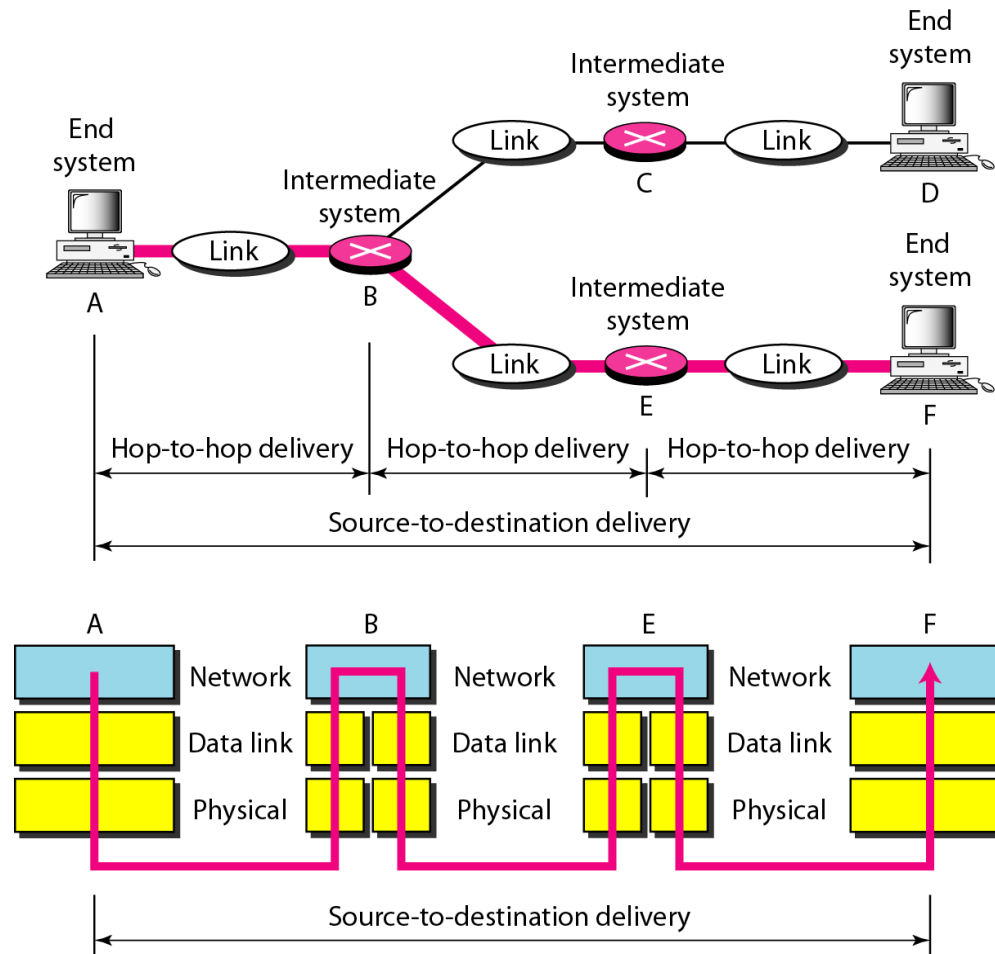

Transport layer

- The transport layer is responsible for the delivery of a message from one process to another.

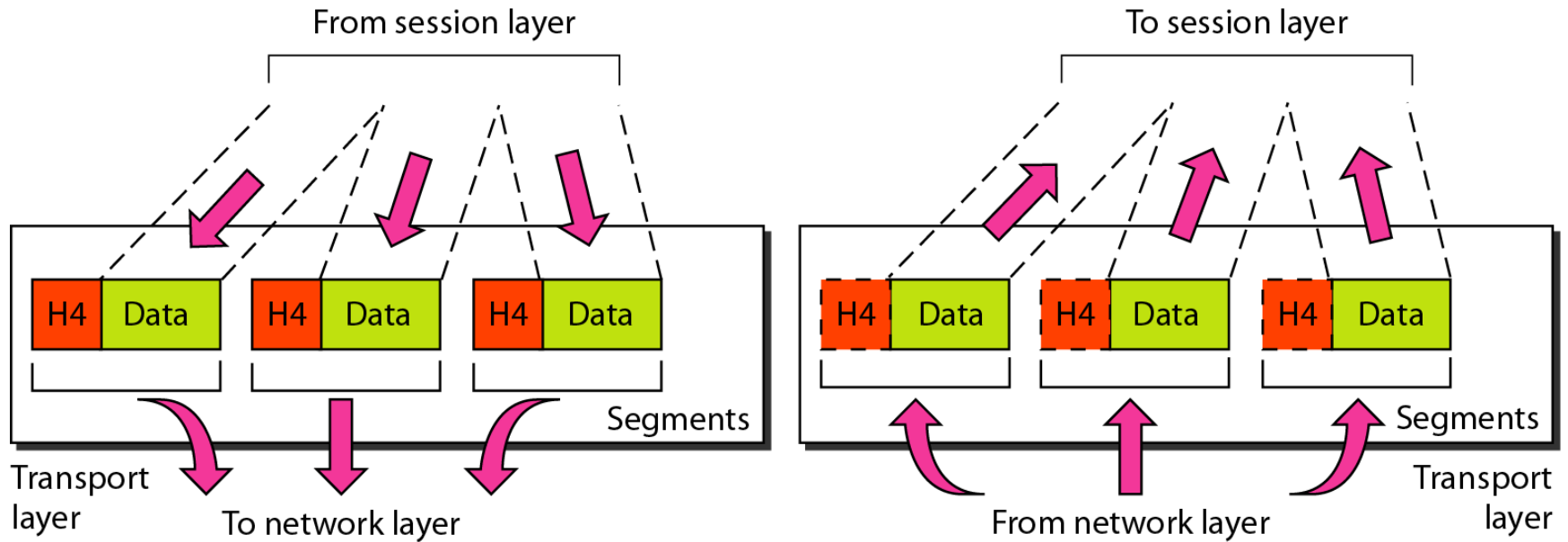

Presentation layer

- The presentation layer is responsible for translation, compression, and encryption.

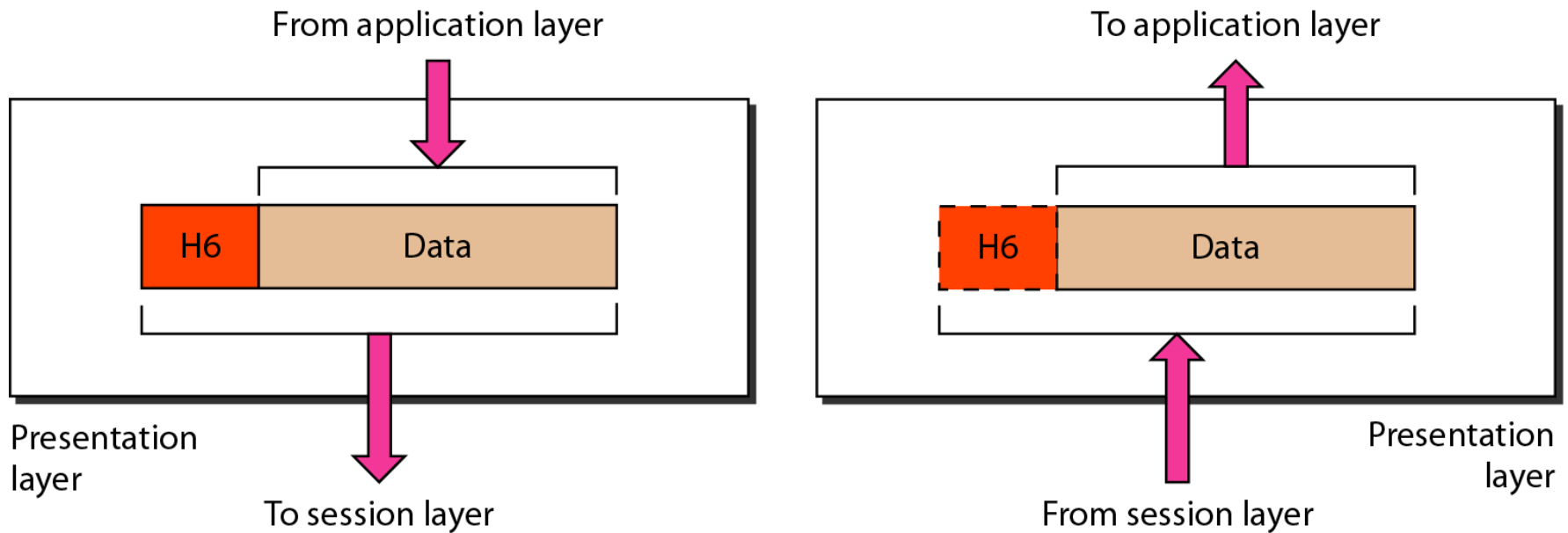

Application layer

- The application layer is responsible for providing services to the user.

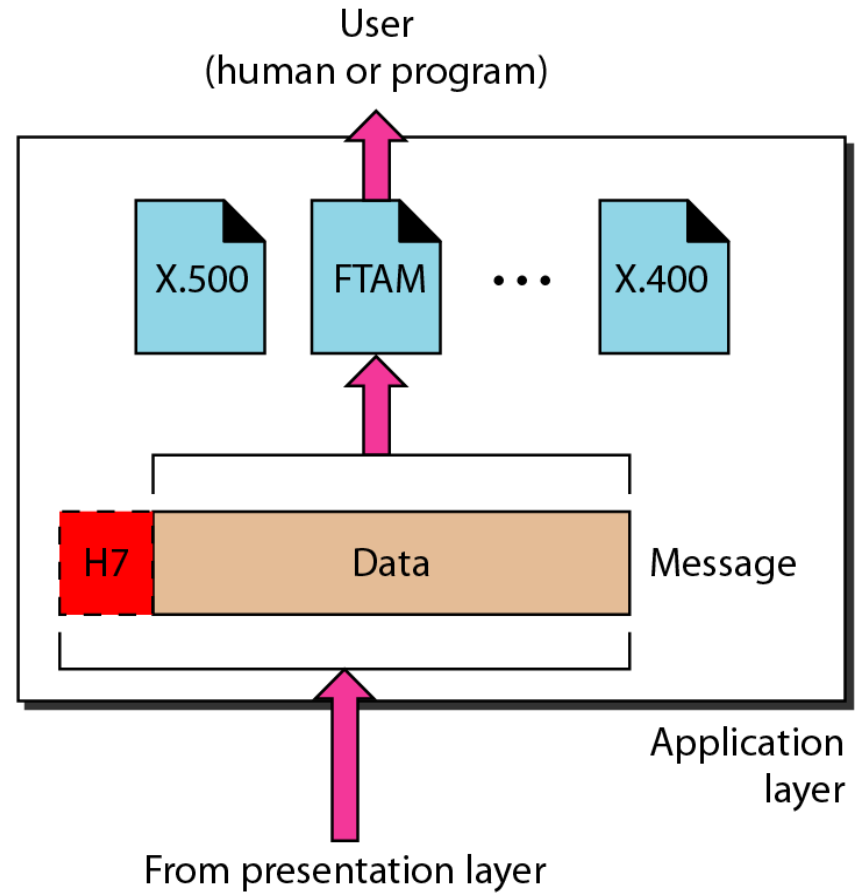
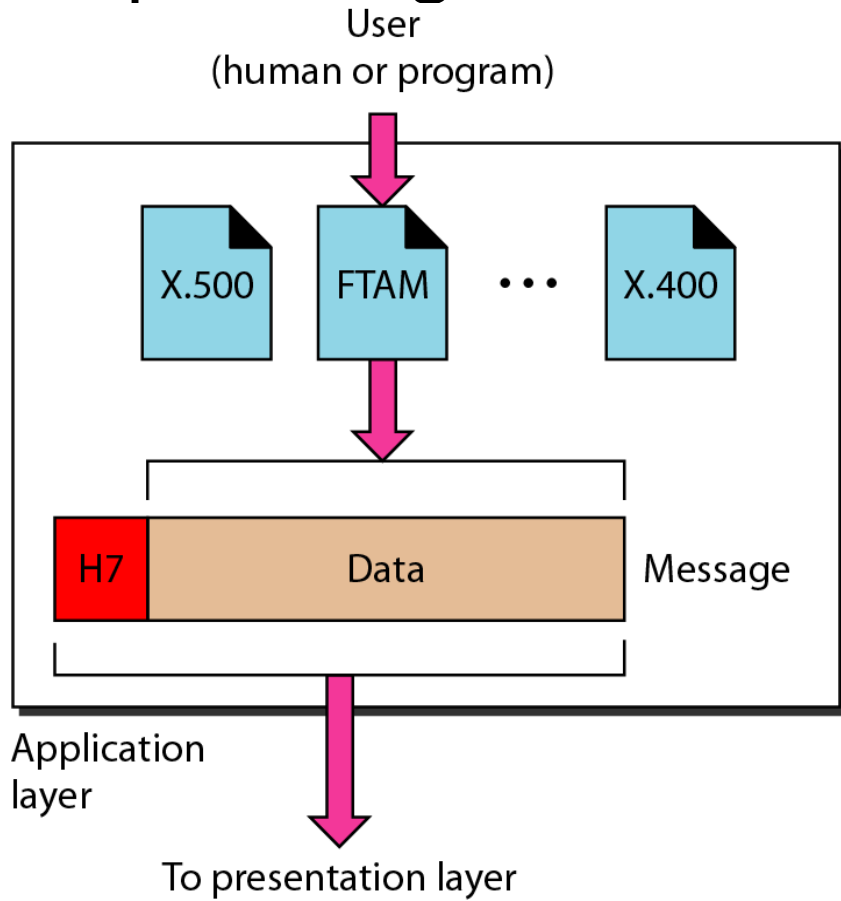

Summary of layers

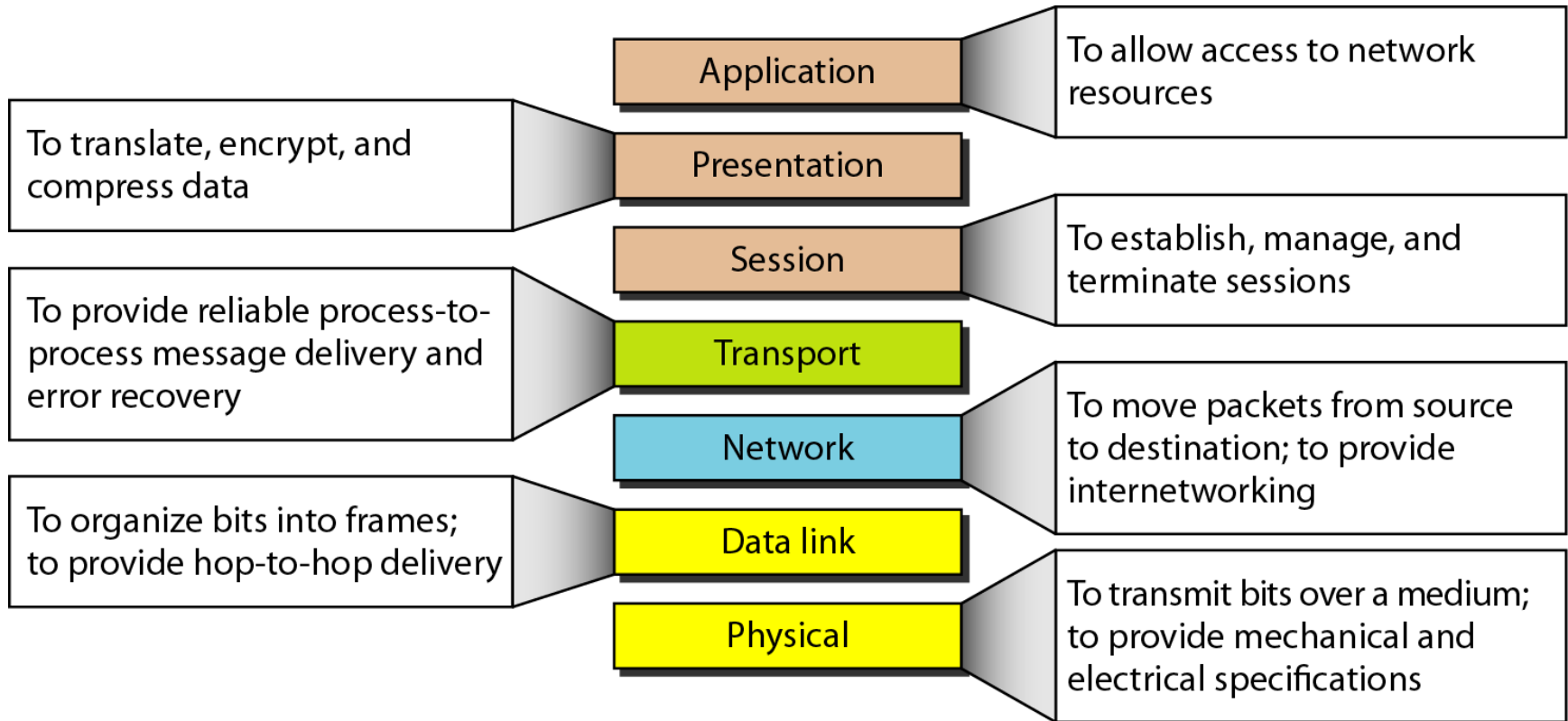

TCP/IP PROTOCOL SUITE

- *The layers in the **TCP/IP protocol suite** do not exactly match those in the OSI model.*
- *The original TCP/IP protocol suite was defined as having four layers: **host-to-network, internet, transport, and application.***
- *However, when TCP/IP is compared to OSI, we can say that the TCP/IP protocol suite is made of five layers: **physical, data link, network, transport, and application.***

Text and Reference Books:

- A. S Tanenbaum, “Computer Networks, PHI
- Forouzan, “Data Communication and Networking”, TMH