

# PROBLEMS ON BLOCK DIAGRAM REDUCTION TECHNIQUES

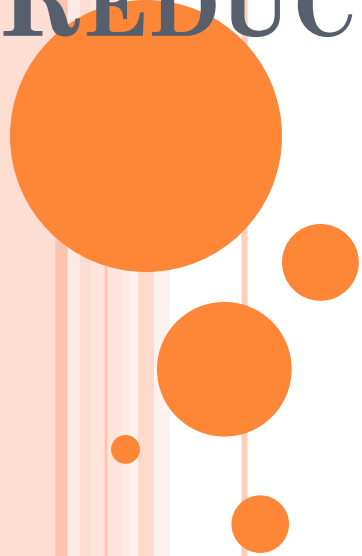

Example-8: For the system represented by the following block diagram determine:

1. Open loop transfer function
2. Feed Forward Transfer function
3. control ratio
4. feedback ratio
5. error ratio
6. closed loop transfer function
7. characteristic equation
8. closed loop poles and zeros if  $K=10$ .

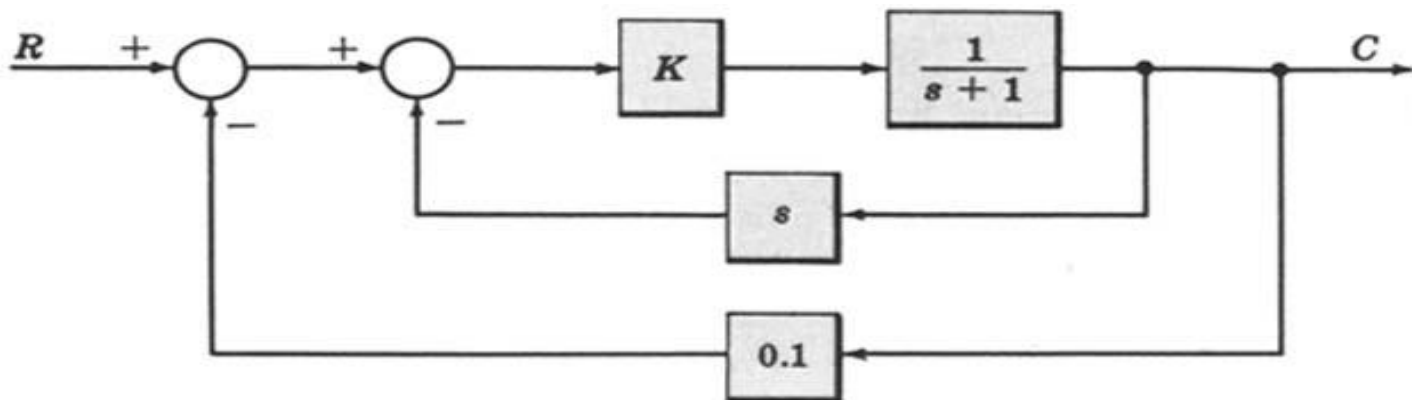

## EXAMPLE-8: CONTINUE

- First we will reduce the given block diagram to canonical form

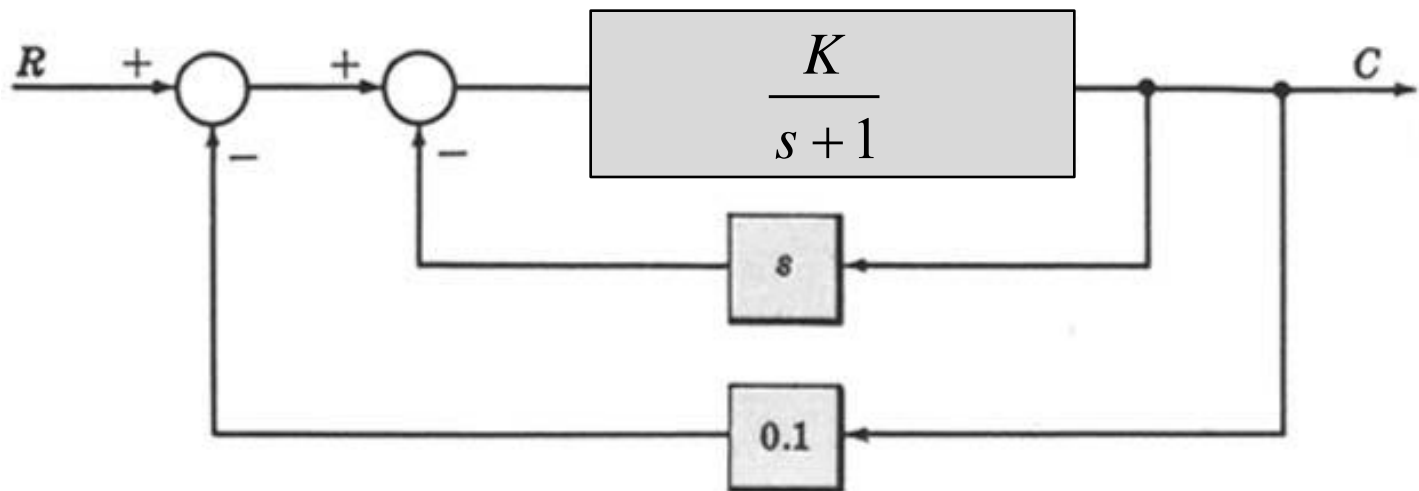
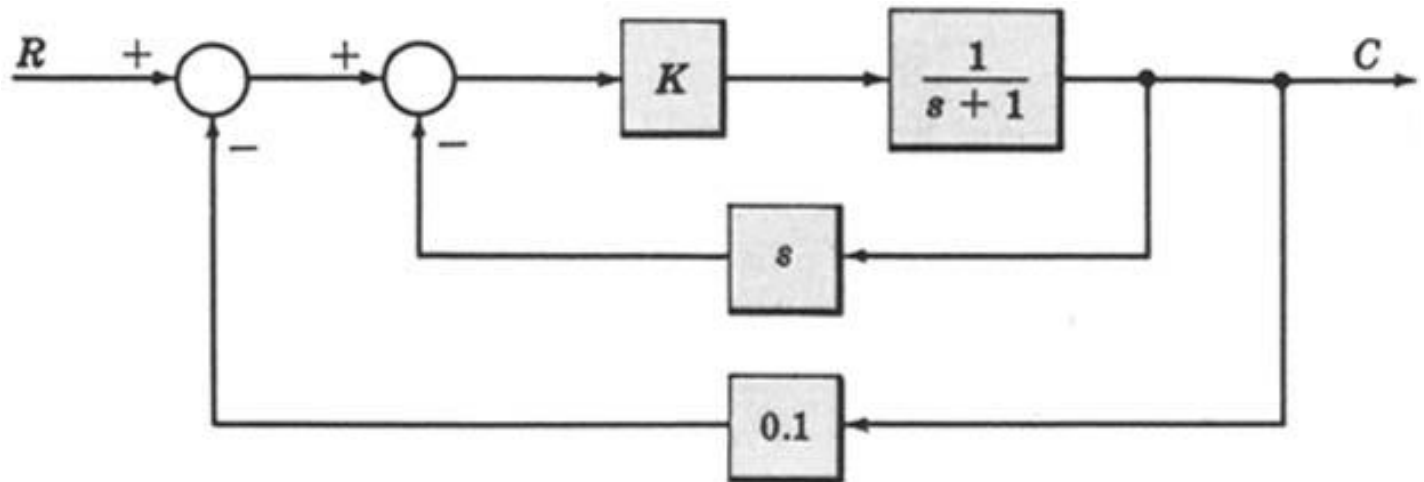

## EXAMPLE-8: CONTINUE

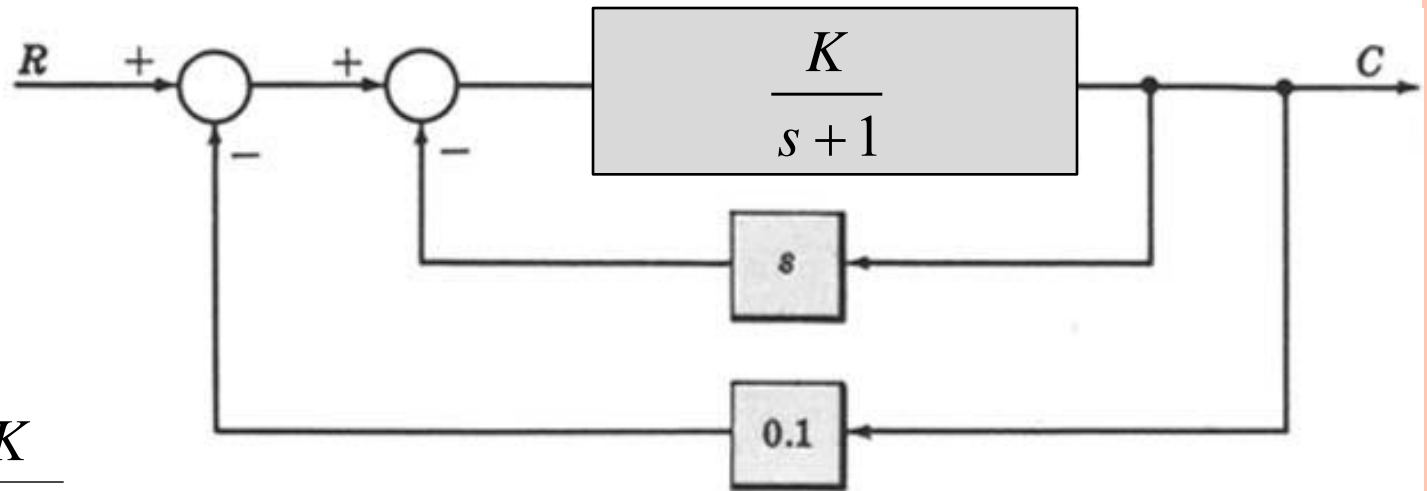

$$\frac{G}{1+GH} = \frac{\frac{K}{s+1}}{1 + \frac{K}{s+1}s}$$

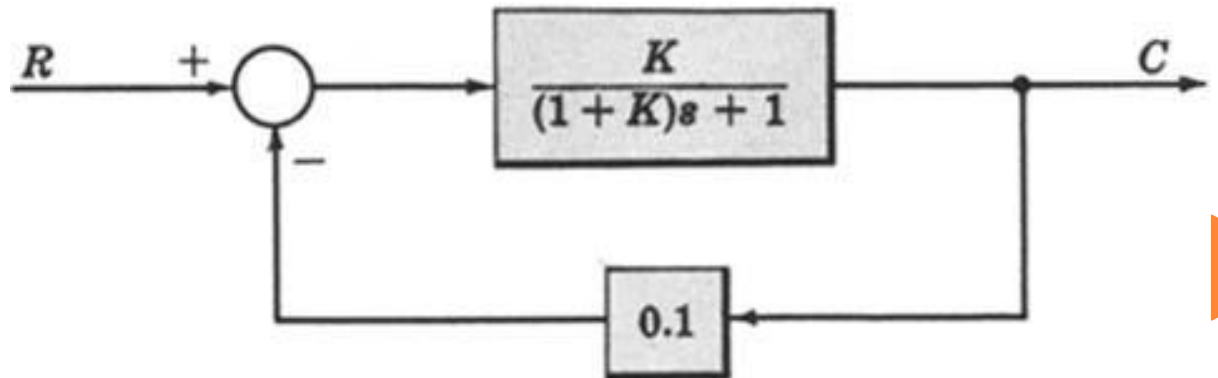

## EXAMPLE-8: CONTINUE

1. Open loop transfer function  $\frac{B(s)}{E(s)} = G(s)H(s)$

2. Feed Forward Transfer function  $\frac{C(s)}{E(s)} = G(s)$

3. control ratio  $\frac{C(s)}{R(s)} = \frac{G(s)}{1 + G(s)H(s)}$

4. feedback ratio  $\frac{B(s)}{R(s)} = \frac{G(s)H(s)}{1 + G(s)H(s)}$

5. error ratio  $\frac{E(s)}{R(s)} = \frac{1}{1 + G(s)H(s)}$

6. closed loop transfer function  $\frac{C(s)}{R(s)} = \frac{G(s)}{1 + G(s)H(s)}$

7. characteristic equation  $1 + G(s)H(s) = 0$

8. closed loop poles and zeros if  $K=10$ .

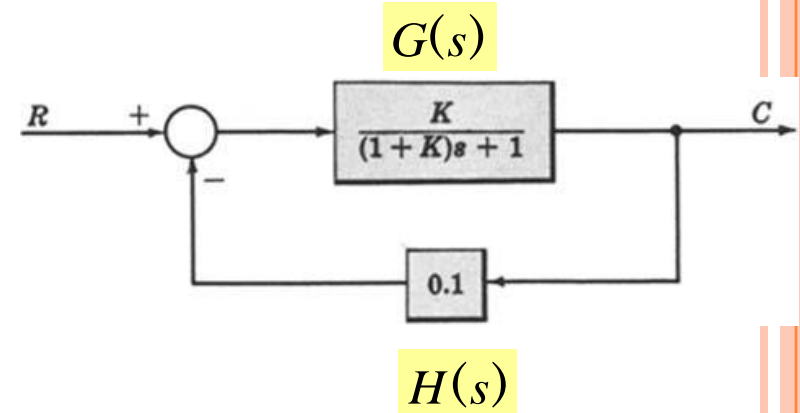

○ Example-9: For the system represented by the following block diagram determine:

1. Open loop transfer function
2. Feed Forward Transfer function
3. control ratio
4. feedback ratio
5. error ratio
6. closed loop transfer function
7. characteristic equation
8. closed loop poles and zeros if  $K=100$ .

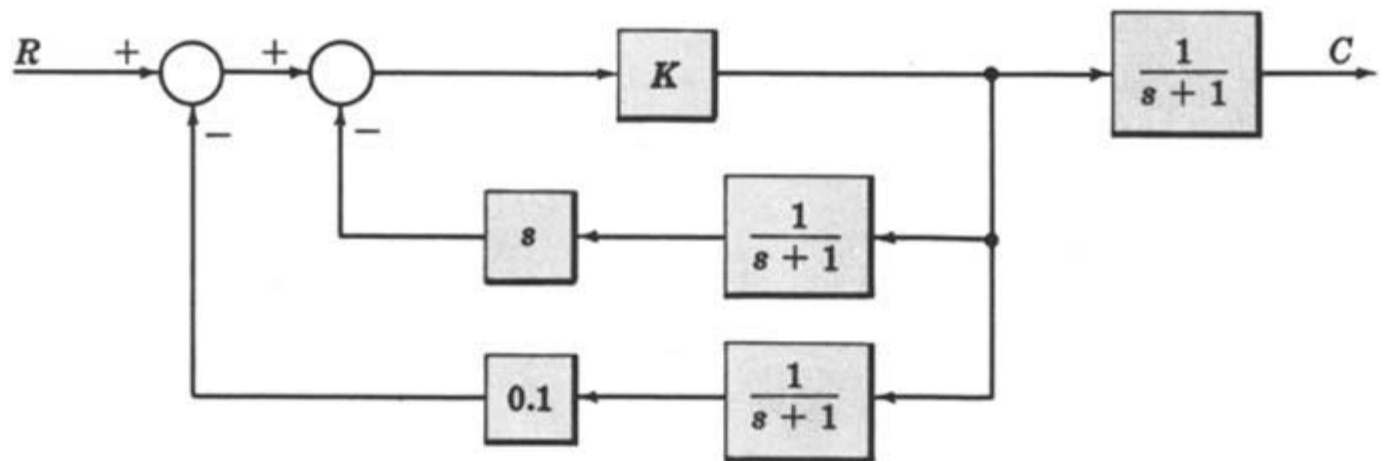

## EXAMPLE-10: REDUCE THE SYSTEM TO A SINGLE TRANSFER FUNCTION.

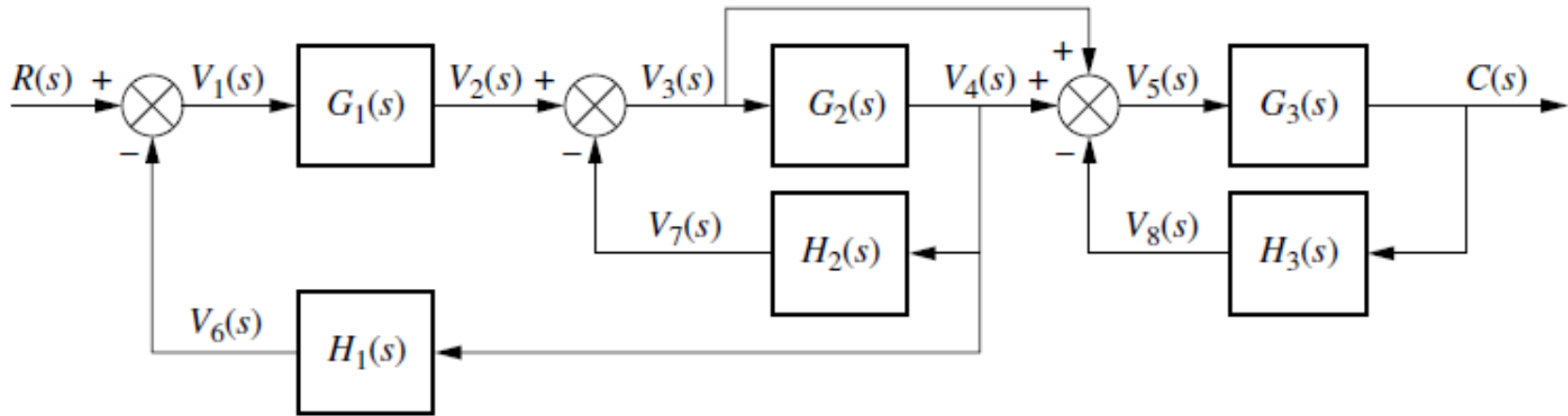

First, move  $G_2(s)$  to the left past the pickoff point to create parallel subsystems, and reduce the feedback system consisting of  $G_3(s)$  and  $H_3(s)$ .

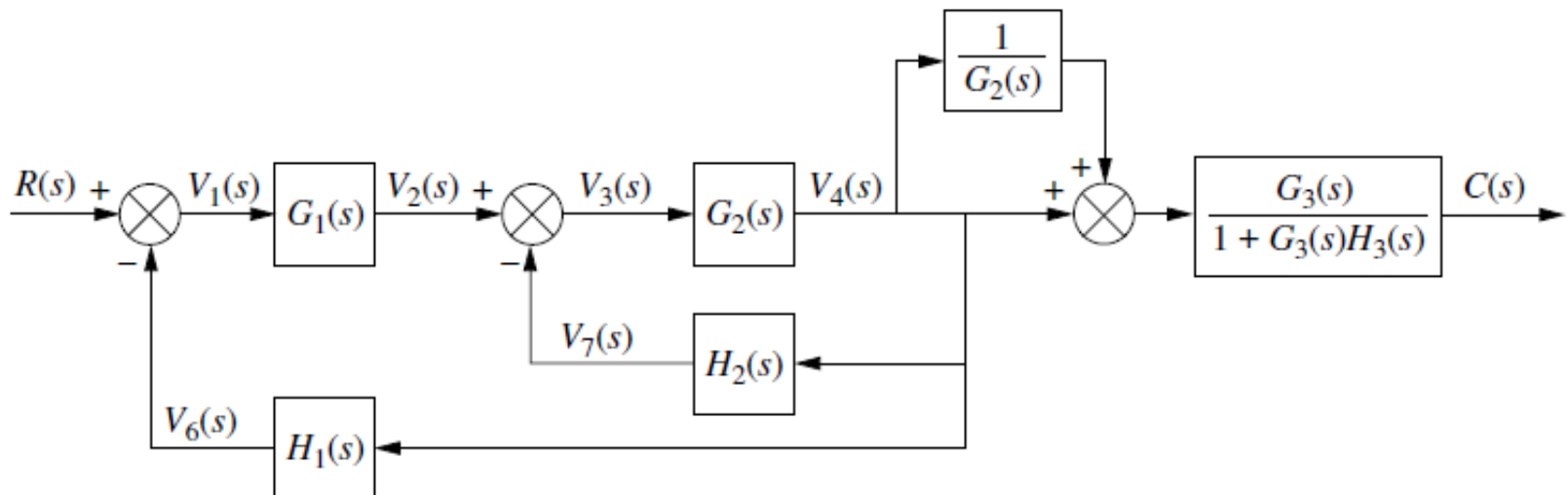

## EXAMPLE-10: CONTINUE.

Second, reduce the parallel pair consisting of  $1/G_2(s)$  and unity, and push  $G_1(s)$  to the right past the summing junction, creating parallel subsystems in the feedback.

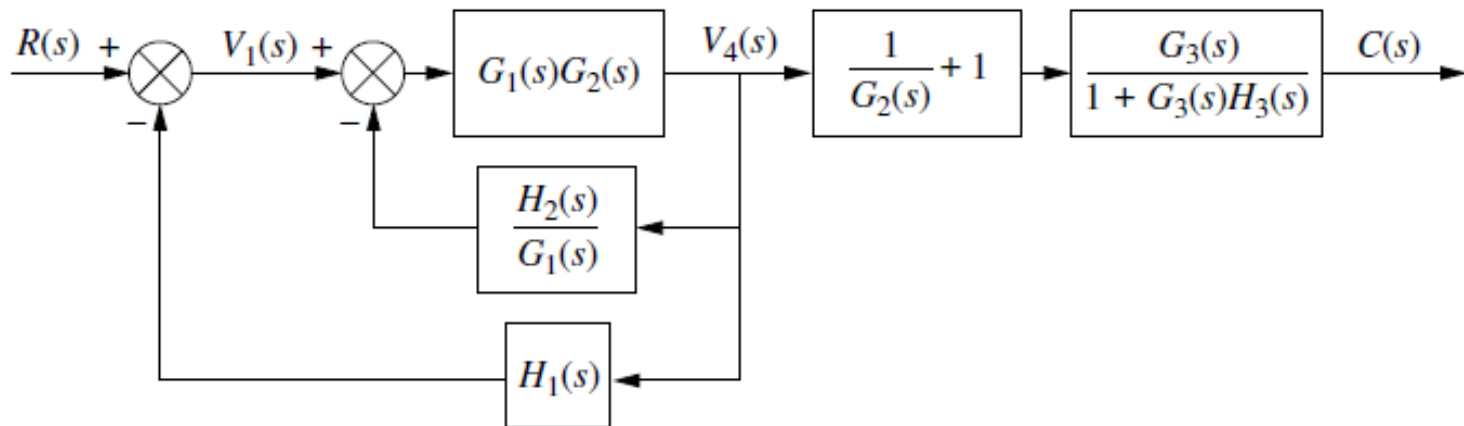

Third, collapse the summing junctions, add the two feedback elements together, and combine the last two cascaded blocks.

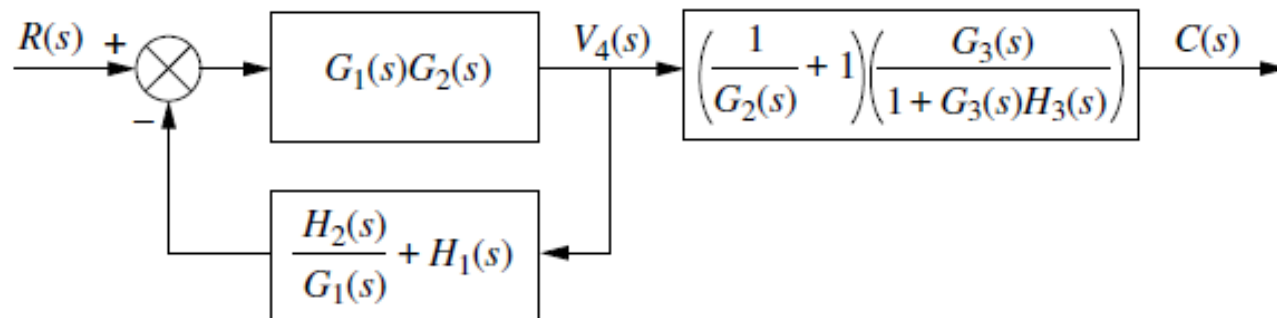



## EXAMPLE-10: CONTINUE.

Fourth, use the feedback formula to obtain Figure

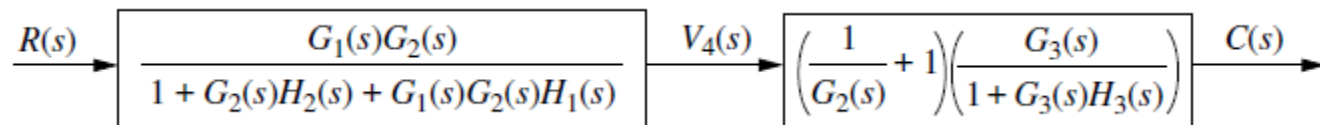

Finally, multiply the two cascaded blocks and obtain the final result,

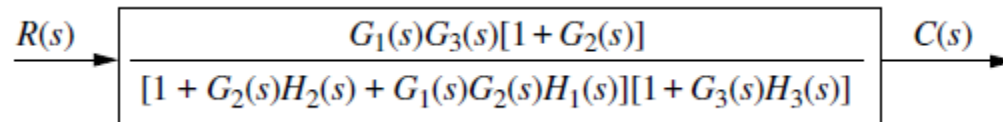

EXAMPLE-11: SIMPLIFY THE BLOCK DIAGRAM THEN OBTAIN THE CLOSE-LOOP TRANSFER FUNCTION  $C(S)/R(S)$ .

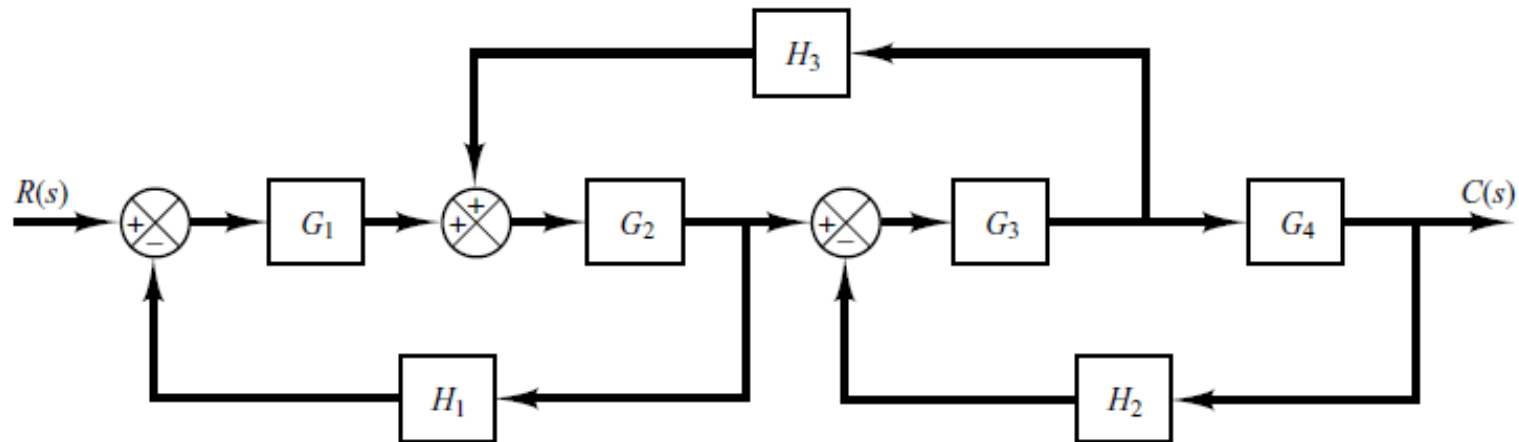

First move the branch point between  $G_3$  and  $G_4$  to the right-hand side of the loop containing  $G_3$ ,  $G_4$ , and  $H_2$ . Then move the summing point between  $G_1$  and  $G_2$  to the left-hand side of the first summing point.

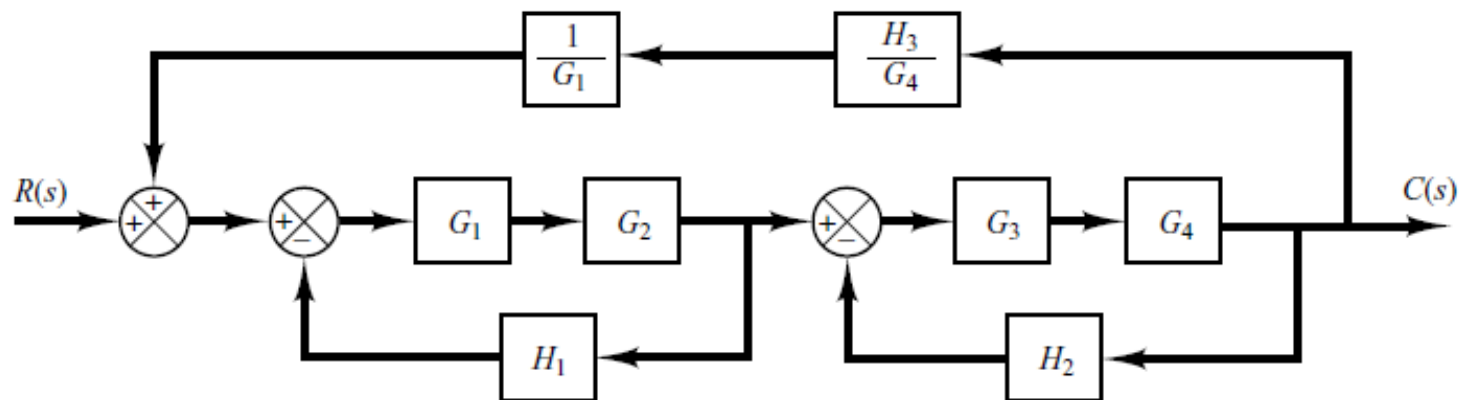

## EXAMPLE-11: CONTINUE.

By simplifying each loop, the block diagram can be modified as

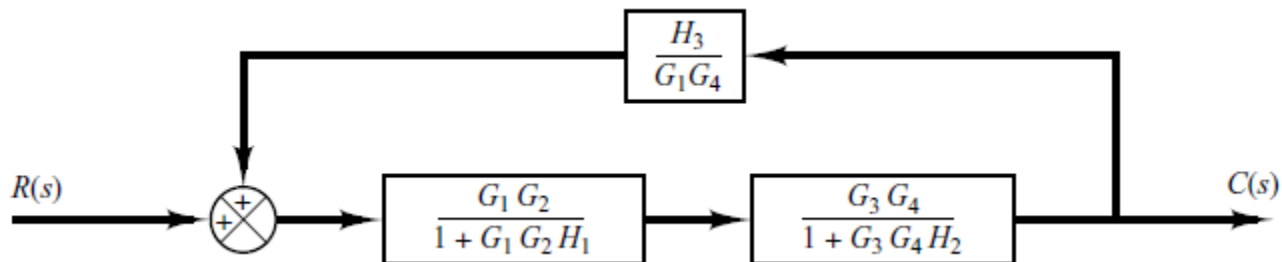

Further simplification results in

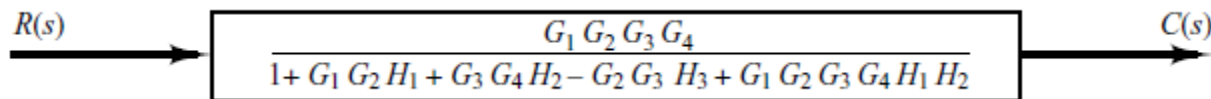

the closed-loop transfer function  $C(s)/R(s)$  is obtained as

$$\frac{C(s)}{R(s)} = \frac{G_1 G_2 G_3 G_4}{1 + G_1 G_2 H_1 + G_3 G_4 H_2 - G_2 G_3 H_3 + G_1 G_2 G_3 G_4 H_1 H_2}$$



## EXAMPLE-12: REDUCE THE BLOCK DIAGRAM.

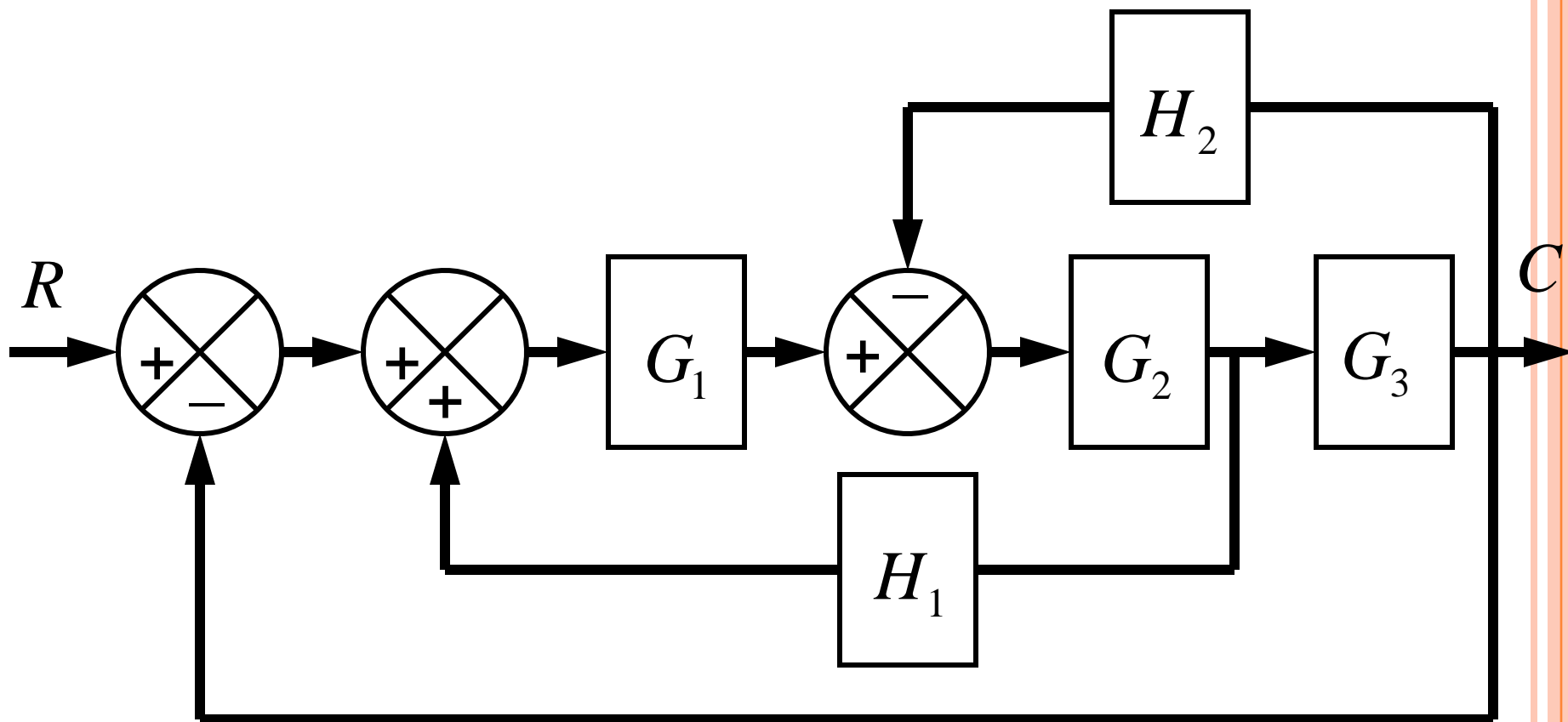

# EXAMPLE-12:

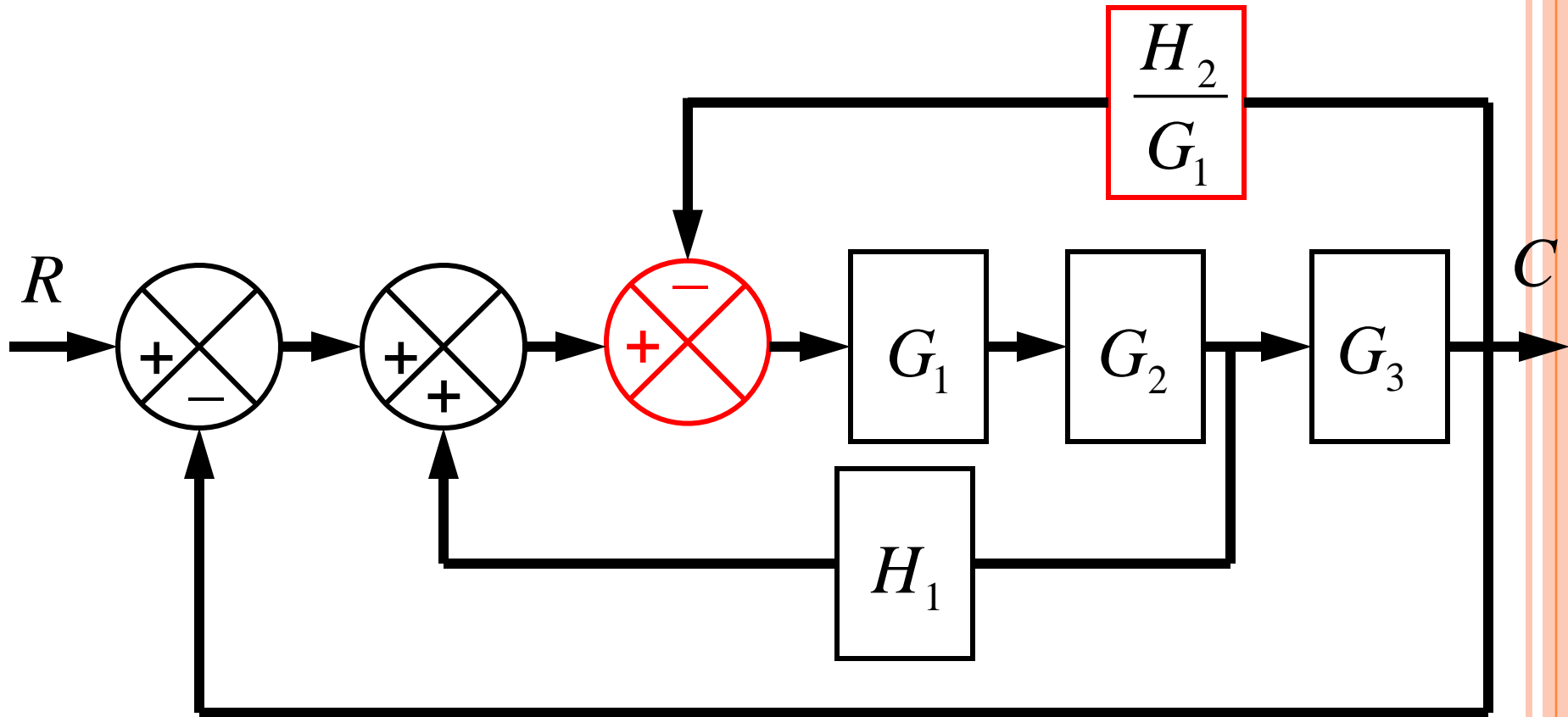

## EXAMPLE-12:

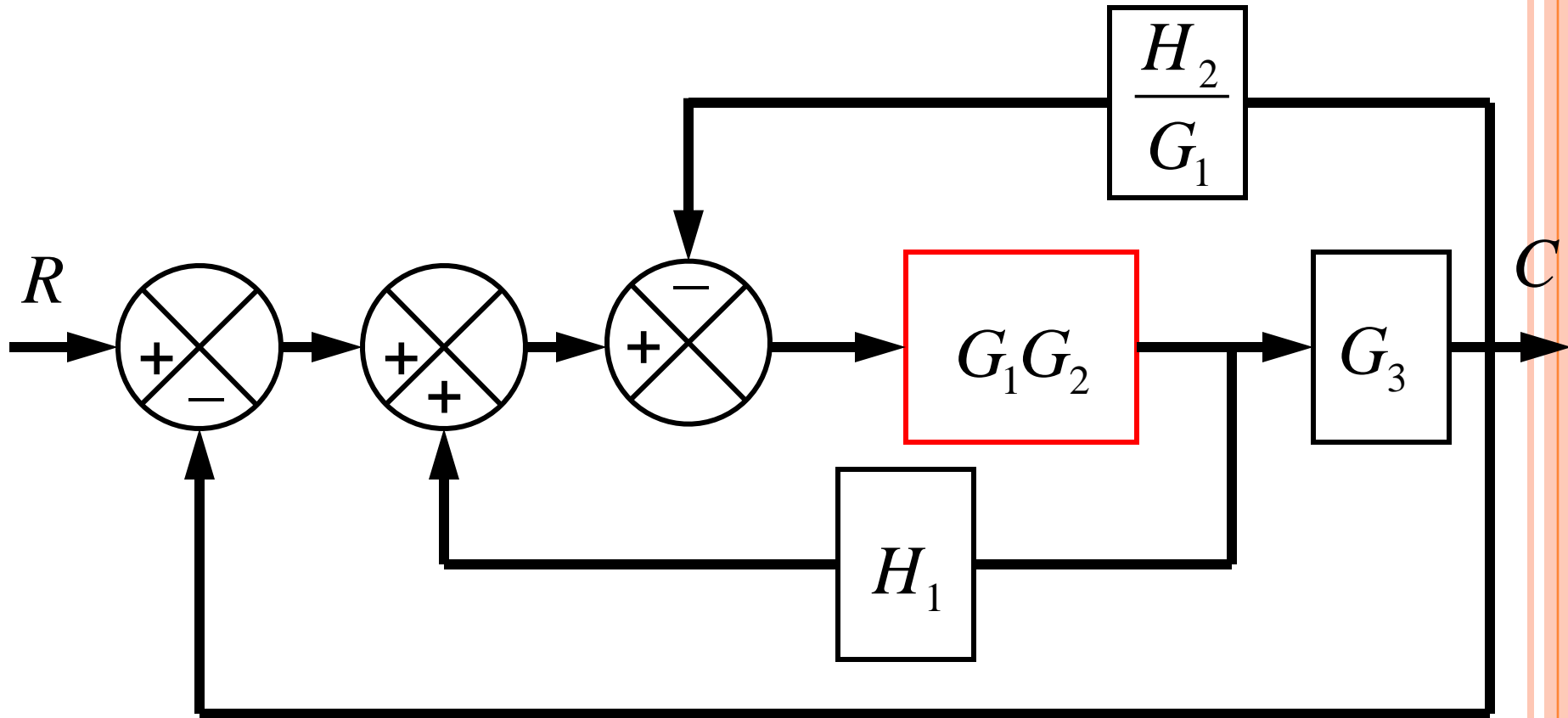

## EXAMPLE-12:

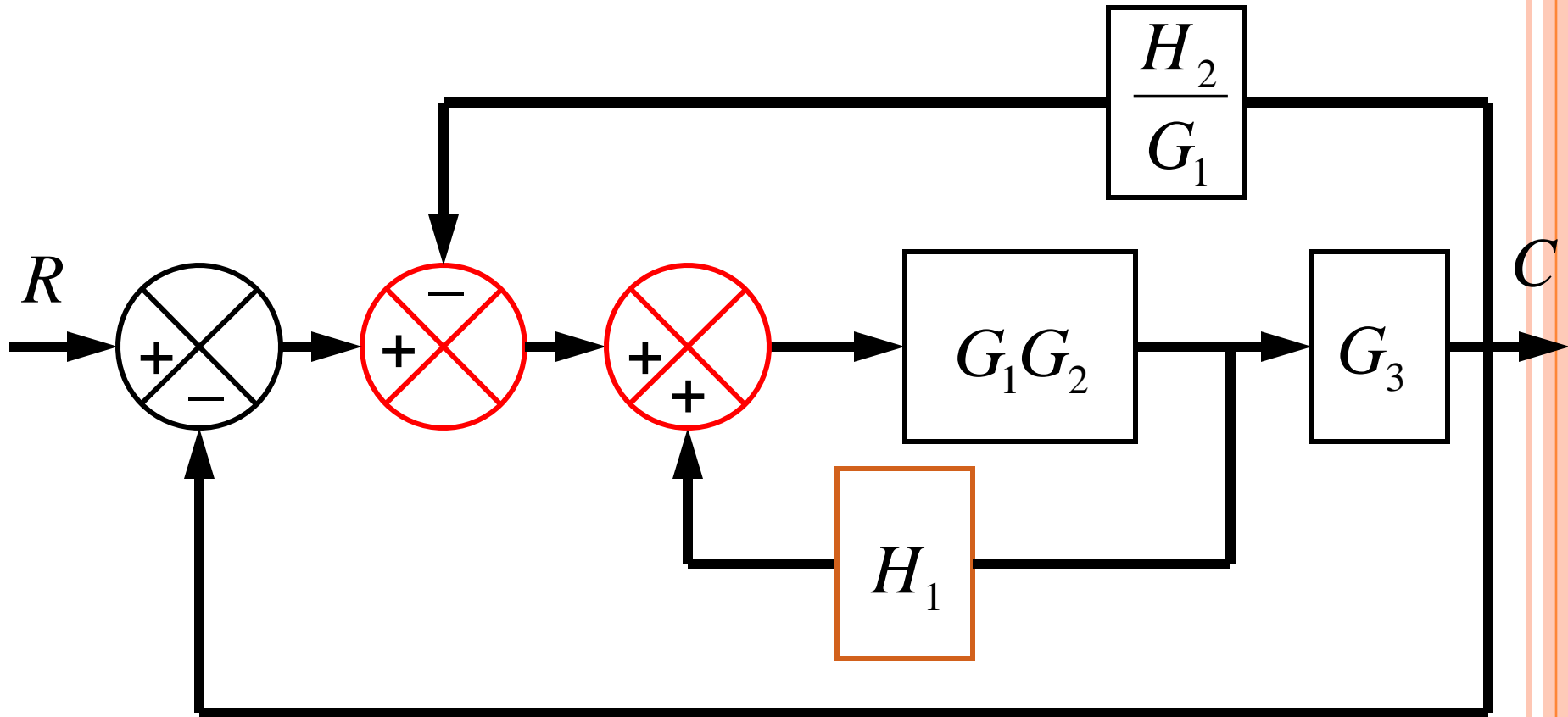

## EXAMPLE-12:

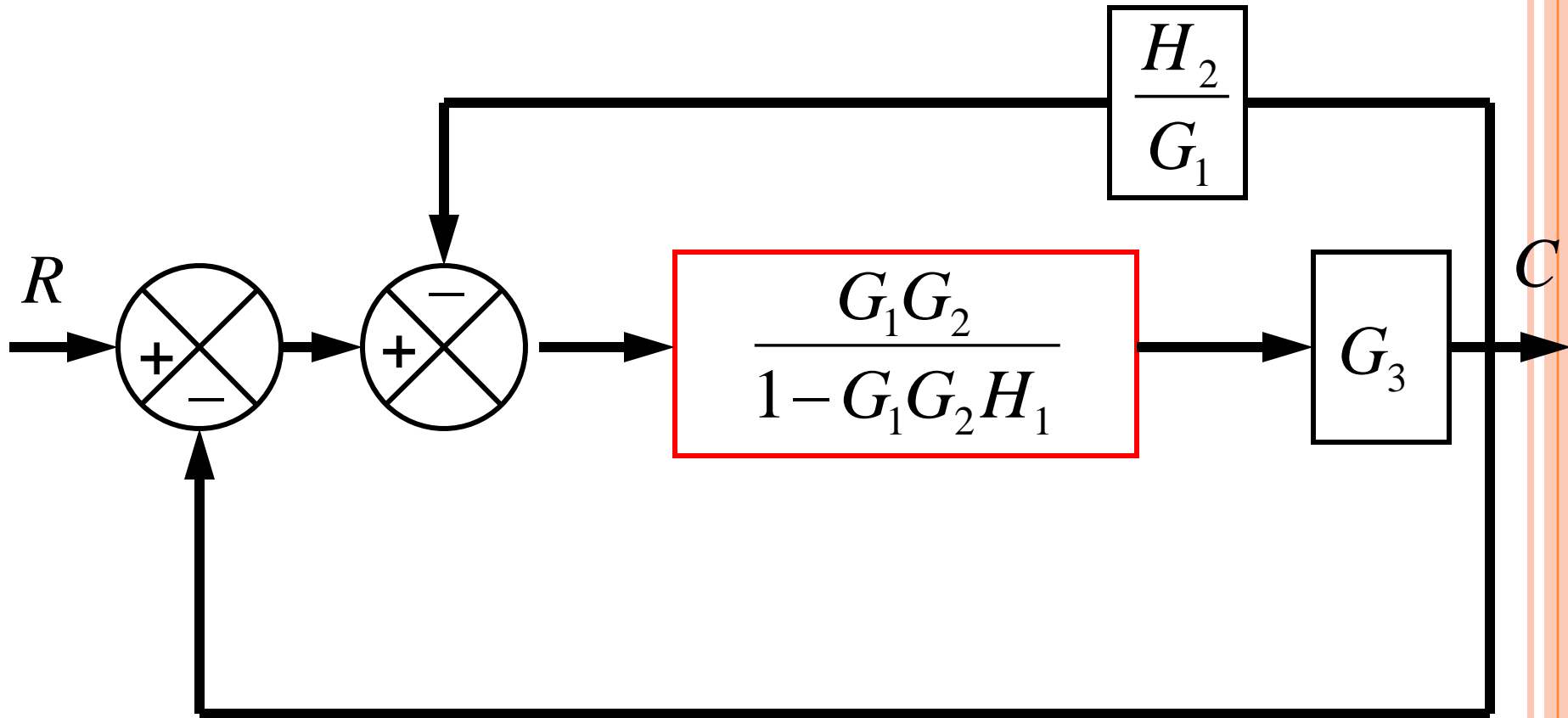



## EXAMPLE-12:

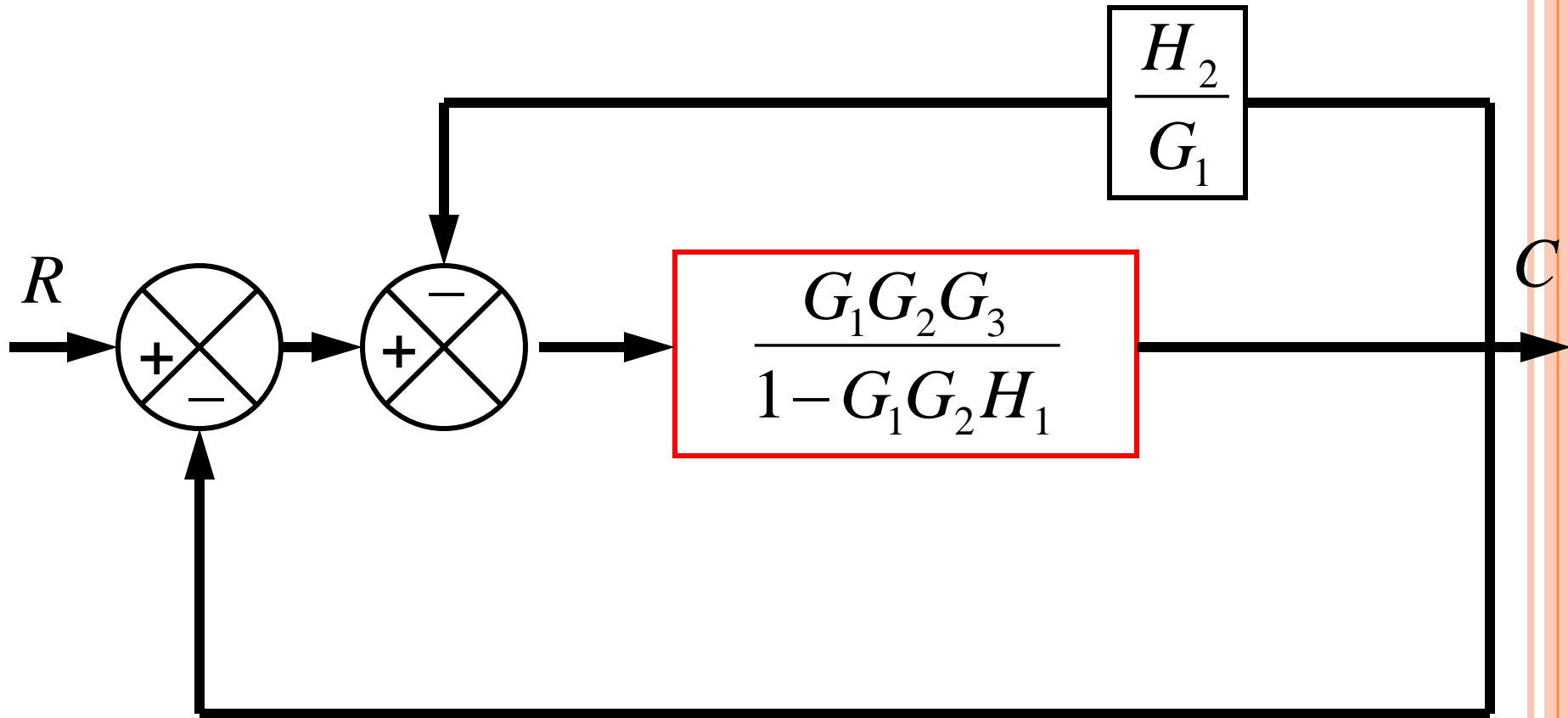

## EXAMPLE-12:

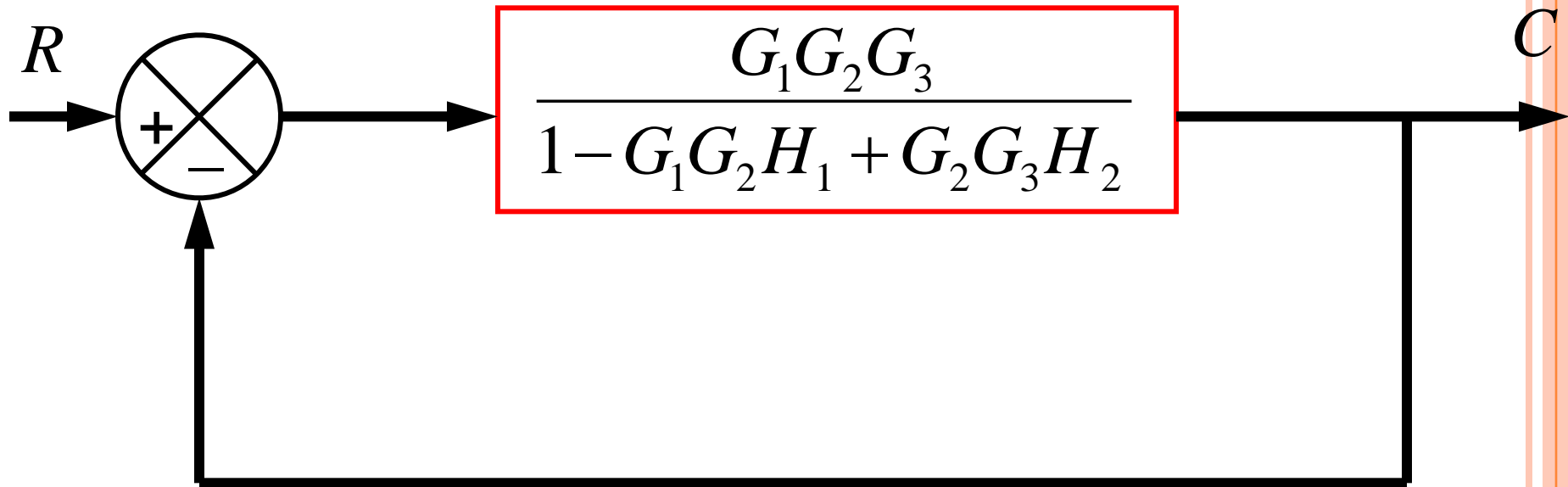

## EXAMPLE-12:

